

THIS DRAWING IS UNPUBLISHED. RELEASED FOR PUBLICATION
 © COPYRIGHT - By - ALL RIGHTS RESERVED.

REVISIONS					
P	LTR	DESCRIPTION	DATE	DWN	APVD
B		UPDATE PER ECO-16-002588	24 FEB 16	CAS	CAS

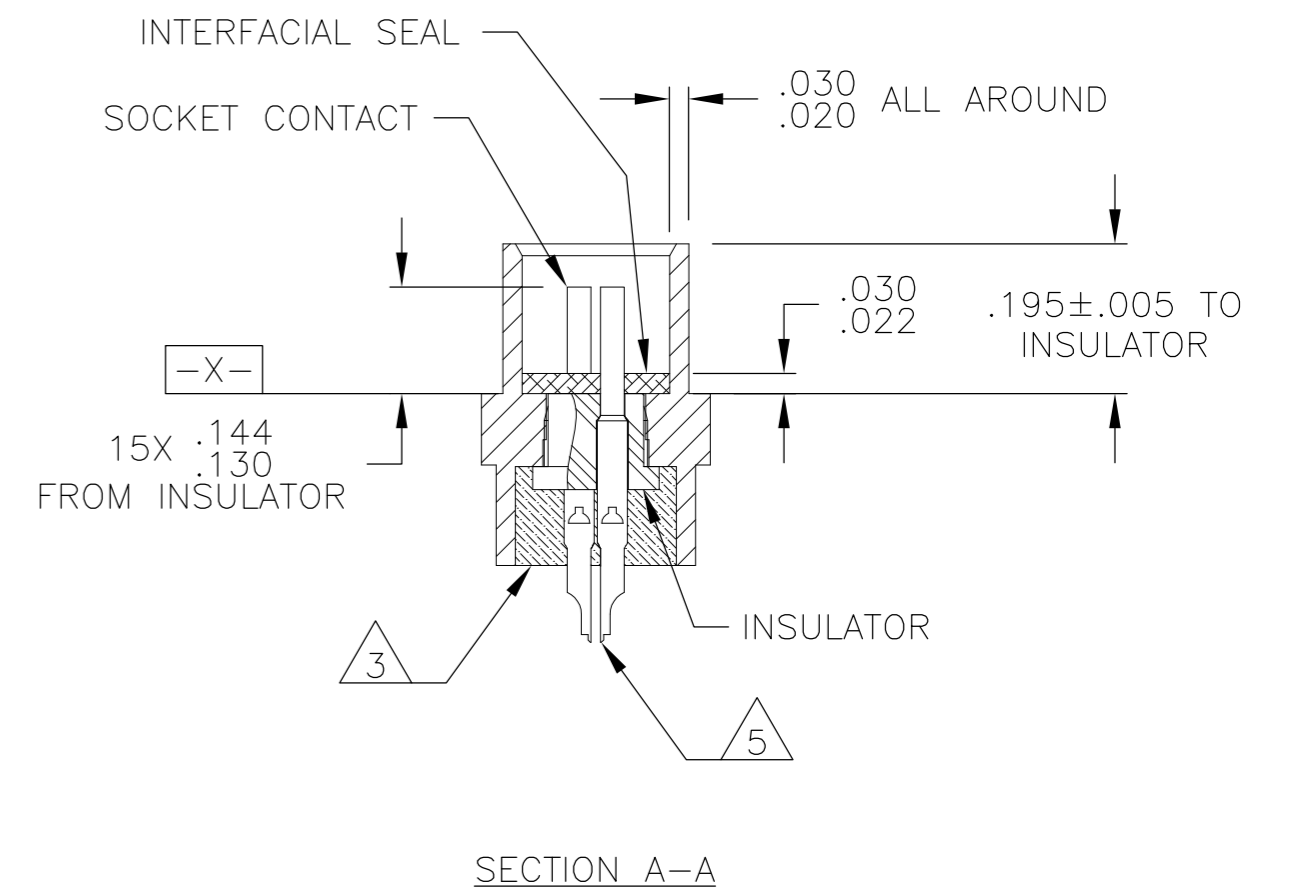
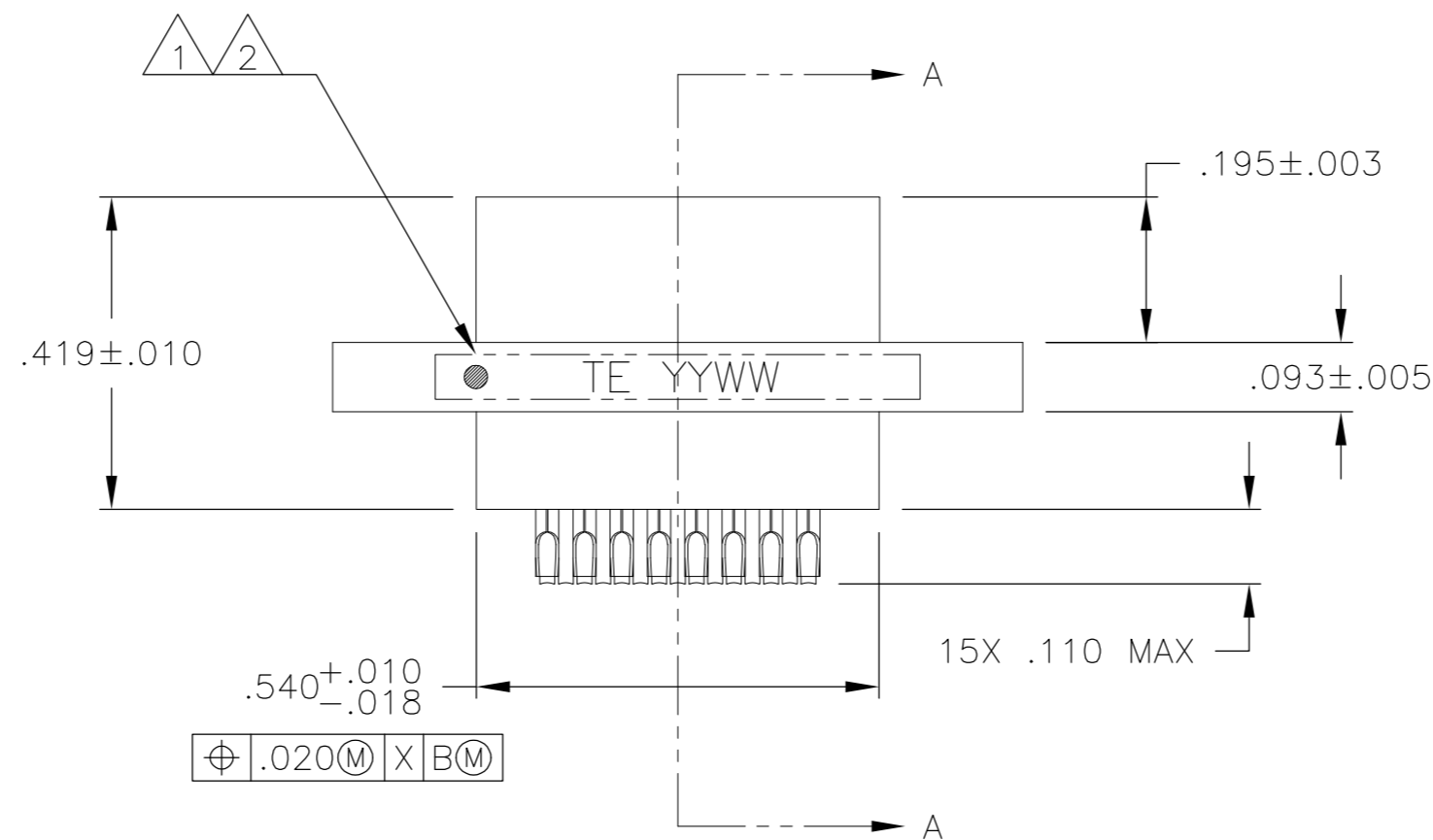
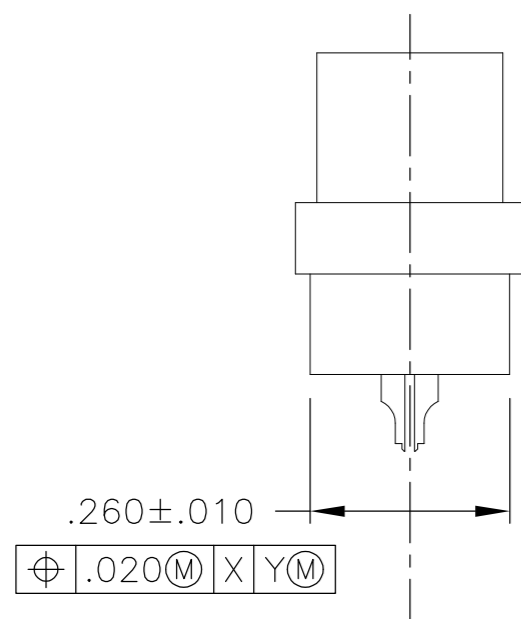
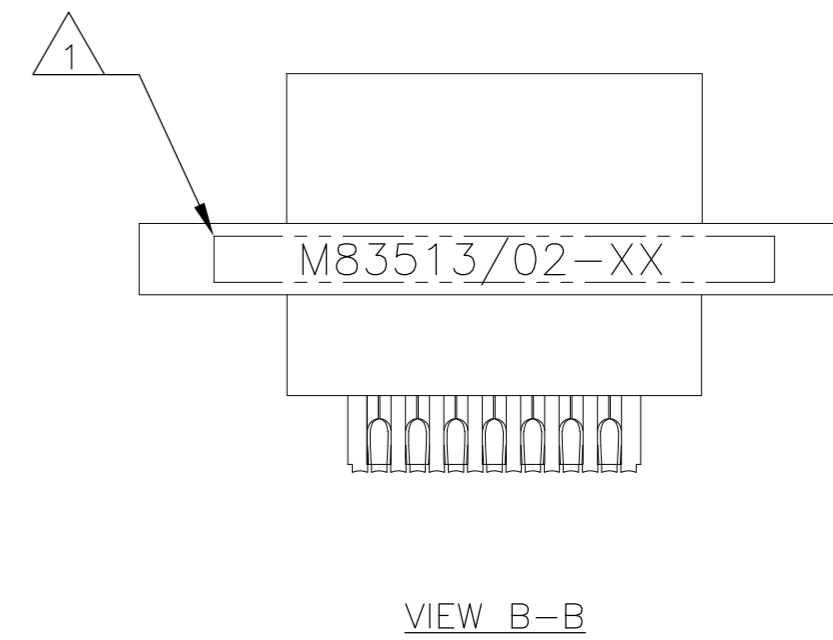
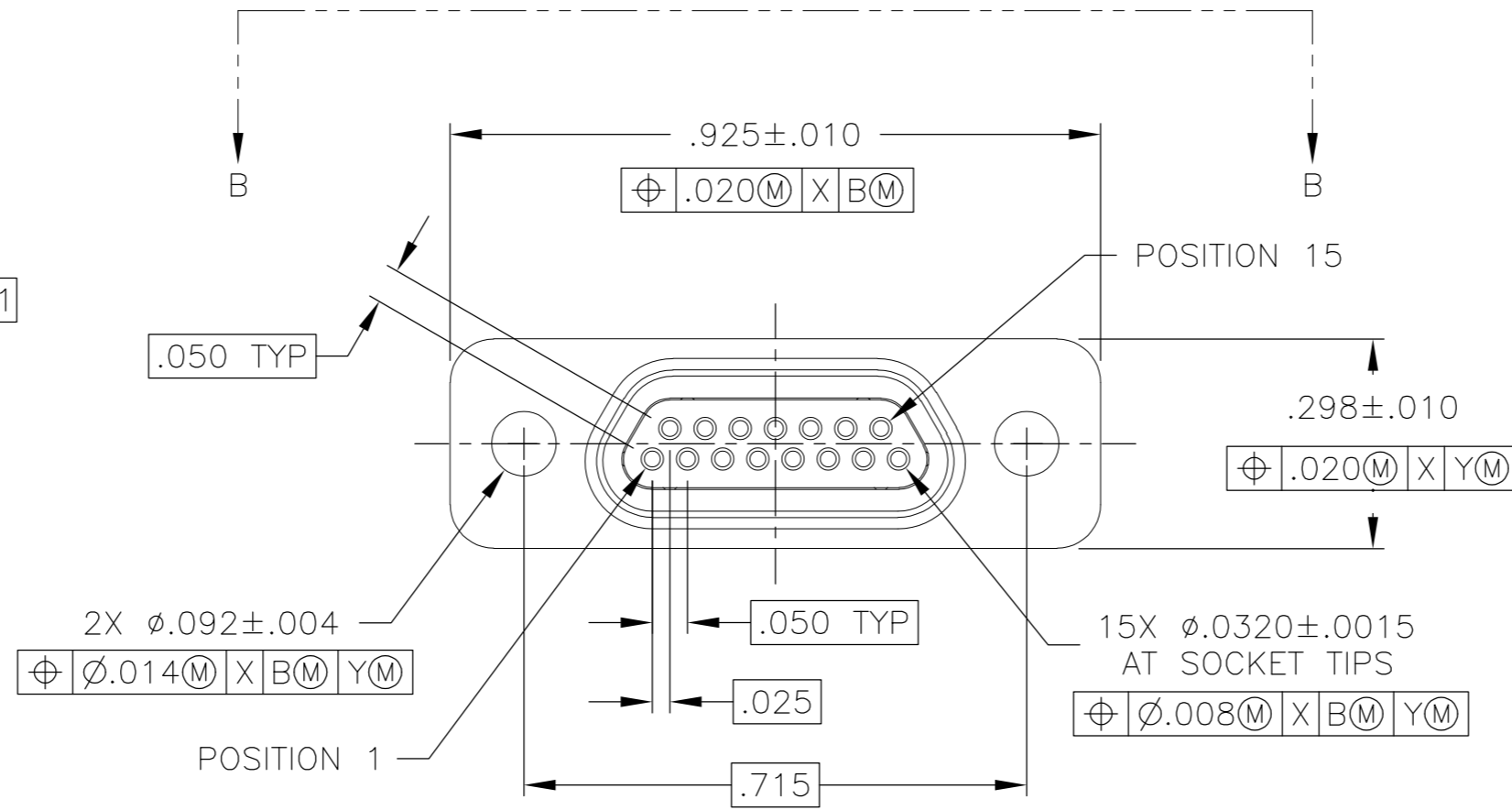
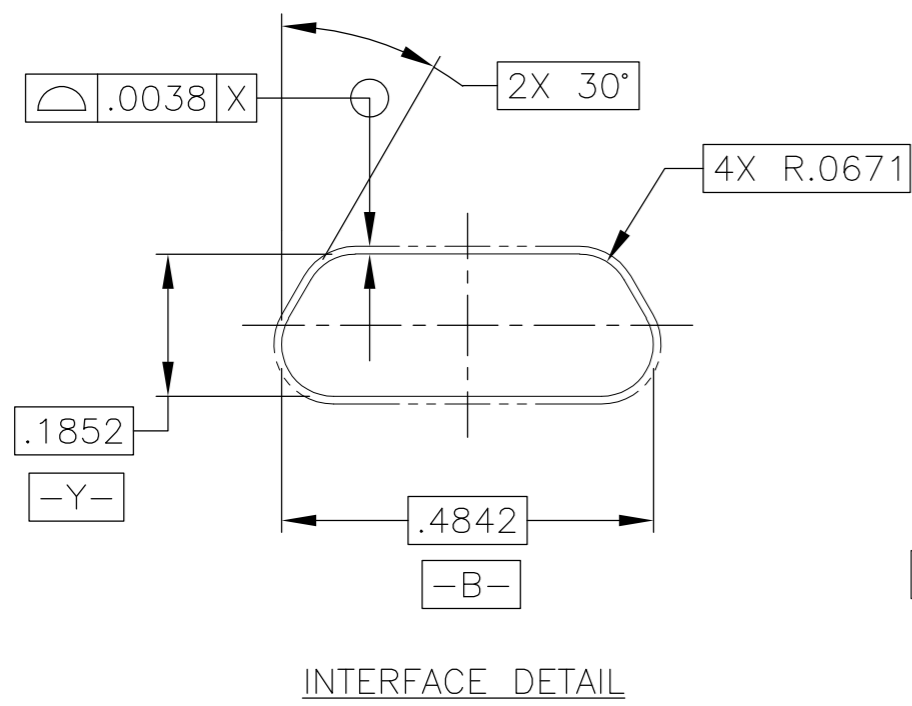

- 1 CONNECTOR SHALL BE MARKED IN ACCORDANCE WITH METHOD I OF MIL-STD-1285. MARKING SHALL CONTAIN THE MILITARY PIN, CAGE CODE (OR TE), AND DATE CODE. EXAMPLE: M83513/02-XX TE YYWW (WHERE XX IS PART OF THE PIN SHOWN IN THE "MIL-DTL-83513" COLUMN OF THE PART NUMBER TABLE, AND YYWW IS THE DATE CODE). FOR THE SIZE 15 RECEPTACLE, THE MARKING MUST BE PRINTED ON BOTH SIDES OF THE FLANGE. TEXT HEIGHT SHALL BE .035 INCH MINIMUM.
- 2 POSITION 1 SHALL BE INDICATED BY AN IDENTIFIABLE MARK, LOCATED APPROXIMATELY AS SHOWN ON THE POSITION 1 SIDE OF THE CONNECTOR FLANGE. THIS MARK SHALL BE INCLUDED AS PART OF THE PART MARKING INFORMATION.
- 3 EPOXY ENCAPSULATION. EPOXY MAY WICK .050 INCH MAX FOR SOLDER CUPS.
- 4 ALL DIMENSIONS AND REQUIREMENTS ARE PER MIL-DTL-83513/2
- 5 CHAMFER ON SOLDER POTS ARE PARALLEL WITH THE SIDE OF CONNECTOR WITHIN 10°

THIS DRAWING IS A CONTROLLED DOCUMENT.		DWN B. ROMANCHUK	03 SEP 08		
DIMENSIONS: INCHES		CHK -	-		
TOLERANCES UNLESS OTHERWISE SPECIFIED:		APVD M. STORRY	03 SEP 08	NAME	
0 PLC ± -		PRODUCT SPEC		RECEPTACLE ASSEMBLY, MICRO-D PER MIL-DTL-83513/02, MCKS SERIES, 15 POSITION	
1 PLC ± -		APPLICATION SPEC		SIZE	RESTRICTED TO
2 PLC ± .010		-		A2	-
3 PLC ± .005		-		CAGE CODE	DRAWING NO
4 PLC ± -		-		98278	1532188
5 ANGLES ± 1°		-		SCALE 4:1 SHEET 1 of 2 REV B	
MATERIAL SEE NOTES		FINISH -		CUSTOMER DRAWING	

