

### General Description

The XR22802 is a Hi-Speed USB 2.0 compound device with an embedded hub and 5 downstream USB functions: 10/100 Ethernet MAC and PHY, 2 UARTs, multi-master capable I<sup>2</sup>C controller, and an Enhanced Dedicated GPIO Entity (EDGE) controller.

The upstream USB interface has an integrated USB 2.0 PHY and device controller that is compliant with both Hi-Speed (480Mbps) and Full-Speed (12Mbps) USB 2.0. The vendor ID, product ID, power mode, remote wakeup support and maximum power consumption are amongst the values that can be programmed using the on-chip One-Time Programmable (OTP) memory.

The 10/100 Ethernet MAC and PHY is compliant with IEEE 802.3 and supports auto-negotiation, auto-MDIX, checksum offload, auto-polarity correction in 10Base-T and remote wakeup capabilities.

The enhanced UART has a maximum data rate of 15 Mbps. Using a fractional baud rate generator, any baud rate between 300 bps and 15 Mbps can be accurately generated. In addition, the UART has a large 1024-byte TX FIFO and RX FIFO to optimize the overall data throughput for various applications. The automatic RS485 control feature simplifies both the hardware and software for half-duplex RS-485 applications. If required, the multidrop (9-bit) mode feature further simplifies typical multidrop applications by enabling / disabling the UART receiver depending on the address byte received.

The multi-master capable I<sup>2</sup>C controller and EDGE controller (up to 32 GPIOs) can be accessed via the USB HID interface. The EDGE pins or I<sup>2</sup>C interface can be used for controlling and monitoring other peripherals. Up to 2 EDGE pins can be configured as a PWM generator.

### FEATURES

- USB 2.0 Compliant Interface
- 10/100 Ethernet MAC and PHY
- Enhanced UART
- I<sup>2</sup>C Multi-master
- Enhanced Dedicated GPIO Entity (EDGE)
- Single +5.0V Power Supply Input
- Regulated +3.3V Output Power
- Single 25MHz Crystal
- ±15kV HBM ESD Protection on USB data pins
- ±8kV HBM ESD Protection on all other pins
- USB CDC-ACM, CDC-ECM and HID compliant
- Custom Software Drivers

### APPLICATIONS

- USB to Ethernet Dongles
- POS Terminals
- Test Instrumentation
- Networking
- Factory Automation and Process Controls
- Industrial Applications

Ordering Information – [Back Page](#)

### Block Diagram

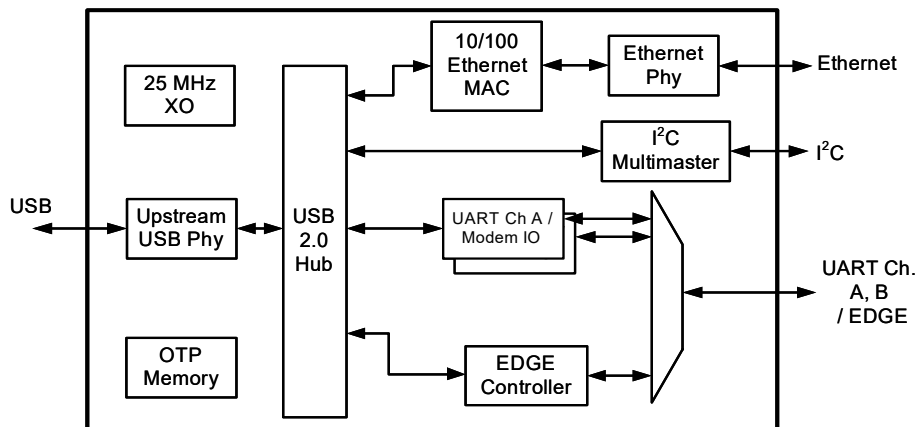

## Extended Features

- USB 2.0 Compliant Interface
  - Integrated USB 2.0 PHY
  - Supports 480 Mbps USB Hi-Speed and 12 Mbps USB Full-Speed data rate
  - Supports USB suspend, resume and remote wakeup operations
  - Compatible with USB CDC-ECM and CDC-ACM
- 10/100 Ethernet MAC and PHY
  - Compliant with IEEE 802.3
  - Integrated 10/100 Ethernet MAC and PHY
  - 10BASE-T and 100BASE-TX support
  - Full-duplex and half-duplex support
  - Full-duplex and half-duplex flow control
  - Preamble generation and removal
  - Automatic 32-bit CRC generation and checking
  - Automatic payload padding and pad removal
  - Diagnostic loop-back modes
  - TCP/UDP/IP/ICMP checksum offload support
  - Flexible Address filtering modes
  - Wakeup packet support
  - Support for 2 status LEDs
- Enhanced UART features
  - Data rates up to 15 Mbps
  - Fractional Baud Rate Generator
  - 1024 byte TX and RX FIFOs
  - 7, 8 or 9 data bits, 1 or 2 stop bits
  - Automatic Hardware Flow Control
  - Automatic Software Flow Control
  - Multidrop (9-bit) mode
  - Auto RS-485 Half-Duplex Control
- I<sup>2</sup>C Multi-master
  - Up to 400 kbps transfers
  - Multi-master capable
- Enhanced Dedicated GPIO Entity (EDGE)
  - Parallel GPIO access
  - Two PWM generators
- Custom software drivers
  - Windows XP, Vista, 7, 8, 8.1 and 10
  - Windows CE 6.0
  - Linux
  - Mac OS X

## Absolute Maximum Ratings

Stresses beyond the limits listed below may cause permanent damage to the device. Exposure to any Absolute Maximum Rating condition for extended periods may affect device reliability and lifetime.

$V_{CC}$  Supply Voltage.....+5.75V

Input Voltage

(all pins except SCL, SDA, USBD+, USBD-).....-0.3 to +4.0V

Input Voltage (USBD+ and USBD-).....-0.3V to +5.75V

Input Voltage (SCL and SDA).....-0.3V to +6.0V

Junction Temperature.....125°C

## Operating Conditions

Operating Temperature Range.....-40°C to +85°C

$V_{CC}$  Supply Voltage.....+4.4V to +5.25V

## Electrical Characteristics

Unless otherwise noted:  $T_A = -40^{\circ}\text{C}$  to  $+85^{\circ}\text{C}$ ,  $V_{CC} = 4.4\text{V}$  to  $5.25\text{V}$

Symbol	Parameter	Conditions	Min	Typ	Max	Units
Power Consumption						
$I_{CC}$	Operating Current	No load on GPIO pins or 3V3_OUT		185	250	mA
$I_{SUSP}$	Suspend Mode Current	No load on GPIO pins or 3V3_OUT		3	4.5	mA
UART, VBUS_SENSE, LOW_PWR# and EDGE Pins						
$V_{IL}$	Input Low Voltage		-0.3		0.8	V
$V_{IH}$	Input High Voltage		2.0		3.6	V
$V_{OL}$	Output Low Voltage	$I_{OL} = 4\text{mA}$			0.3	V
$V_{OH}$	Output High Voltage	$I_{OL} = -4\text{mA}$	2.2			V
$I_{IL}$	Input Low Leakage Current				$\pm 10$	$\mu\text{A}$
$I_{IH}$	Input High Leakage Current				$\pm 10$	$\mu\text{A}$
$C_{IN}$	Input Pin Capacitance				5	pF
USB I/O Pins						
$V_{OL}$	Output Low Voltage	Full-speed USB. External $15\text{k}\Omega$ to GND on USBD+ and USBD- pins	0		0.3	V
$V_{OH}$	Output High Voltage	Full-speed USB. External $15\text{k}\Omega$ to GND on USBD+ and USBD- pins	2.8		3.6	V
$V_{OL}$	Output Low Voltage	Hi-speed USB. External $45\ \Omega$ to GND on USBD+ and USBD- pins	-300		300	mV
$V_{OH}$	Output High Voltage	Hi-speed USB. External $45\ \Omega$ to GND on USBD+ and USBD- pins	360		440	mV
$V_{DrvZ}$	Driver Output Impedance			45		$\Omega$
$I_{OSC}$	Output Short Circuit Current	1.5V on USBD+ and USBD- pins			52	mA

Symbol	Parameter	Conditions	Min	Typ	Max	Units
Ethernet I/O Pins - 100Base-TX transmit mode						
V <sub>PPH</sub>	Peak Differential Output Voltage High	Measured at line side of transformer, line replaced by differential resistance of 100 ohms.	950		1050	mV
V <sub>PPL</sub>	Peak Differential Output Voltage Low		-950		-1050	mV
V <sub>SAS</sub>	Signal Amplitude Symmetry		98		102	%
T <sub>RF</sub>	Signal Rise and Fall Time		3		5	ns
D <sub>CD</sub>	Duty Cycle Distortion		0		0.5	ns
V <sub>OS</sub>	Overshoot and Undershoot		0		5	%
-	Transmit Jitter	Measured differentially	0		1.4	ns
Ethernet I/O Pins - 10Base-T transmit mode						
V <sub>PPH</sub>	Peak Differential Output Voltage High	Measured at line side of transformer, line replaced by differential resistance of 100 ohms.	2.2		2.8	V
3.3V Regulated Power Output						
V <sub>OUT</sub>	Output Voltage	Max load current 50 mA	3.0	3.3	3.6	V

## Pin Configuration

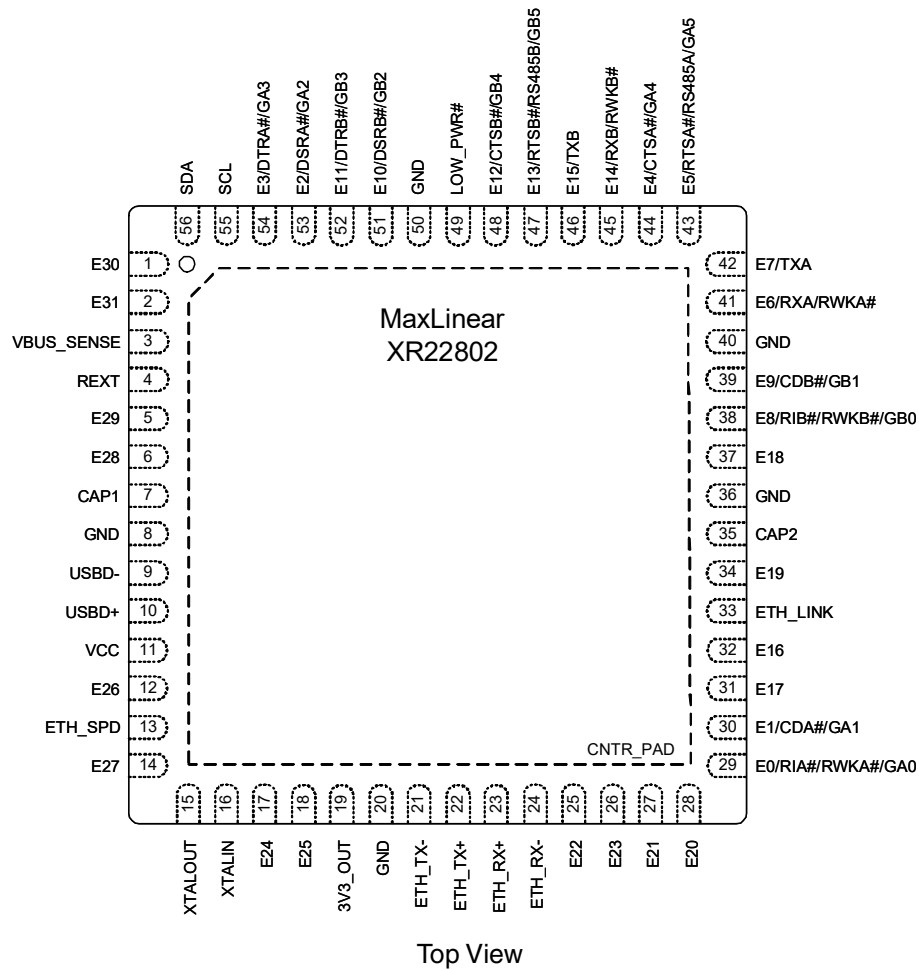

## Pin Assignments

Pin No.	Pin Name	Type	Description
1	E30	I/O	Enhanced general purpose IO. Defaults to input with internal pull-up resistor.
2	E31	I/O	Enhanced general purpose IO. Defaults to input with internal pull-up resistor.
3	VBUS_SENSE	I	VBUS Sense input. In self-powered mode, the VBUS from the USB connector needs to be connected to this pin through a voltage divider circuit (VBUS = 5V, VBUS_SENSE = 3.3V input) using large resistance values to minimize power. It should also be decoupled by a 0.1uF capacitor. This feature may be enabled via the OTP whenever the hub function is configured for self-powered mode. The VBUS_SENSE input is used to disable the pull-up resistor on the USBD+ signal when VBUS is not present. In bus-powered mode, this pin is ignored.
4	REXT	I	Connect externally using short trace to 226 ohm 1% resistor to ground
5	E29	I/O	Enhanced general purpose IO. Defaults to input with internal pull-up resistor.
6	E28	I/O	Enhanced general purpose IO. Defaults to input with internal pull-up resistor.
7	CAP1	I	Connect externally to CAP2 and 3V3_OUT using short trace

Pin No.	Pin Name	Type	Description
8	GND	PWR	Power supply common, ground
9	USBD-	I/O	USB port differential data negative
10	USBD+	I/O	USB port differential data positive
11	VCC	PWR	5.0V power supply input
12	E26	I/O	Enhanced general purpose IO. Defaults to input with internal pull-up resistor.
13	ETH_SPD	O	Ethernet 100 Mbps Speed Indicator. Asserted high for 100 Mbps.
14	E27	I/O	Enhanced general purpose IO. Defaults to input with internal pull-up resistor.
15	XTALOUT	O	Crystal or buffered clock output
16	XTALIN	I	25 MHz +/- 50 ppm Crystal or external clock input
17	E24	I/O	Enhanced general purpose IO. Defaults to input with internal pull-up resistor.
18	E25	I/O	Enhanced general purpose IO. Defaults to input with internal pull-up resistor.
19	3V3_OUT	PWR	3.3 V output power. Connect externally to CAP1 and CAP2 using short trace and decouple with minimum of 4.7uF capacitor
20	GND	PWR	Power supply common, ground
21	ETH_TX-	O	Ethernet transmit data out negative
22	ETH_TX+	O	Ethernet transmit data out positive
23	ETH_RX+	I	Ethernet receive data in positive
24	ETH_RX-	I	Ethernet receive data in negative
25	E22	I/O	Enhanced general purpose IO. Defaults to input with internal pull-up resistor.
26	E23	I/O	Enhanced general purpose IO. Defaults to input with internal pull-up resistor.
27	E21	I/O	Enhanced general purpose IO. Defaults to input with internal pull-up resistor.
28	E20	I/O	Enhanced general purpose IO. Defaults to input with internal pull-up resistor.
29	E0/RIA#/RWKA#/GA0	I/O	Enhanced general purpose IO, or UART channel A Ring Indicator, or remote wakeup, or general purpose IO. Defaults to UART GPIO input. Refer to Remote Wakeup section on <a href="#">page 10</a> .
30	E1/CDA#/GA1	I/O	Enhanced general purpose IO, or UART channel A Carrier Detect, or general purpose IO. Defaults to UART GPIO input.
31	E17	I/O	Enhanced general purpose IO. Defaults to input with internal pull-up resistor.
32	E16	I/O	Enhanced general purpose IO. Defaults to input with internal pull-up resistor.
33	ETH_LINK	O	Ethernet 10/100 Activity Indicator. Toggles with activity.
34	E19	I/O	Enhanced general purpose IO. Defaults to input with internal pull-up resistor.
35	CAP2	I	Connect externally to CAP1 and 3V3_OUT using short trace
36	GND	PWR	Power supply common, ground
37	E18	I/O	Enhanced general purpose IO. Defaults to input with internal pull-up resistor.
38	E8/RIB#/RWKB#/GB0	I/O	Enhanced general purpose IO, or UART channel B Ring Indicator, or remote wakeup, or general purpose IO. Defaults to UART GPIO input. Refer to Remote Wakeup section on <a href="#">page 10</a> .
39	E9/CDB#/GB1	I/O	Enhanced general purpose IO, or UART channel B Carrier Detect, or general purpose IO. Defaults to UART GPIO input.
40	GND	PWR	Power supply common, ground

Pin No.	Pin Name	Type	Description
41	E6/RXA/RWKA#	I/O	Enhanced general purpose IO, or UART channel A RX data, or remote wakeup. Defaults to UART RX data.
42	E7/TXA	I/O	Enhanced general purpose IO, or UART channel A TX data. Defaults to UART TX data.
43	E5/RTSA#/RS485A/GA5	I/O	Enhanced general purpose IO, or UART channel A Request to Send, or auto-RS485 half-duplex enable, or general purpose IO. Defaults to UART GPIO input except when XR22802 is used with CDC-ACM driver. Refer to Automatic RTS/CTS Hardware Flow Control section on <a href="#">page 14</a> or Auto RS-485 Half-Duplex Control on <a href="#">page 15</a> .
44	E4/CTSA#/GA4	I/O	Enhanced general purpose IO, or UART channel A Clear to Send, or general purpose IO. Defaults to UART GPIO input except when XR22802 is used with CDC-ACM driver. Refer to Automatic RTS/CTS Hardware Flow Control section on <a href="#">page 14</a> .
45	E14/RXB/RWKB#	I/O	Enhanced general purpose IO, or UART channel B RX data, or remote wakeup. Defaults to UART RX data.
46	E15/TXB	I/O	Enhanced general purpose IO, or UART channel B TX data. Defaults to UART TX data.
47	E13/RTSB#/RS485B/GB5	I/O	Enhanced general purpose IO, or UART channel B Request to Send, or channel B auto-RS485 half-duplex enable, or general purpose IO. Defaults to UART GPIO input except when XR22802 is used with CDC-ACM driver. Refer to Automatic RTS/CTS Hardware Flow Control section on <a href="#">page 14</a> or Auto RS-485 Half-Duplex Control on <a href="#">page 15</a> .
48	E12/CTSB#/GB4	I/O	Enhanced general purpose IO, or UART channel B Clear to Send, or general purpose IO. Defaults to UART GPIO input except when XR22802 is used with CDC-ACM driver. Refer to Automatic RTS/CTS Hardware Flow Control section on <a href="#">page 14</a> .
49	LOW_PWR#	O	The LOW_PWR# pin will be asserted whenever it is not safe to draw the amount of current requested from VBUS in the Device Maximum Power field of the Configuration Descriptor. The LOW_PWR# pin is asserted when the XR22802 is in suspend mode or when it is not yet configured. The LOW_PWR# pin will be de-asserted whenever it is safe to draw the amount of current requested in the Device Maximum Power field. Note that the XR22802 device is a high power device. The default polarity of the LOW_PWR# output pin is active low and is programmable via the OTP.
50	GND	PWR	Power supply common, ground
51	E10/DSRB#/GB2	I/O	Enhanced general purpose IO, or UART channel B Data Set Ready, or general purpose IO. Defaults to UART GPIO input. Refer to Automatic DTR/DSR Hardware Flow Control section on <a href="#">page 14</a> .
52	E11/DTRB#/GB3	I/O	Enhanced general purpose IO, or UART channel B Data Terminal Ready, or general purpose IO. Defaults to UART GPIO input. Refer to Automatic DTR/DSR Hardware Flow Control section on <a href="#">page 14</a> .
53	E2/DSRA#/GA2	I/O	Enhanced general purpose IO, or UART channel A Data Set Ready, or general purpose IO. Defaults to UART GPIO input. Refer to Automatic DTR/DSR Hardware Flow Control section on <a href="#">page 14</a> .
54	E3/DTRA#/GA3	I/O	Enhanced general purpose IO, or UART channel A Data Terminal Ready, or general purpose IO. Defaults to UART GPIO input. Refer to Automatic DTR/DSR Hardware Flow Control section on <a href="#">page 14</a> .
55	SCL	I/O OD	I <sup>2</sup> C Master controller serial clock (open-drain) External pull-up resistor required on this pin.
56	SDA	I/O OD	I <sup>2</sup> C Master controller data (open-drain). External pull-up resistor required on this pin.
	CNTR_PAD	PWR	Must be connected to ground.

Type: I = Input, O = Output, I/O = Input/Output, PWR = Power, OD = Open-Drain

Functional Block Diagram

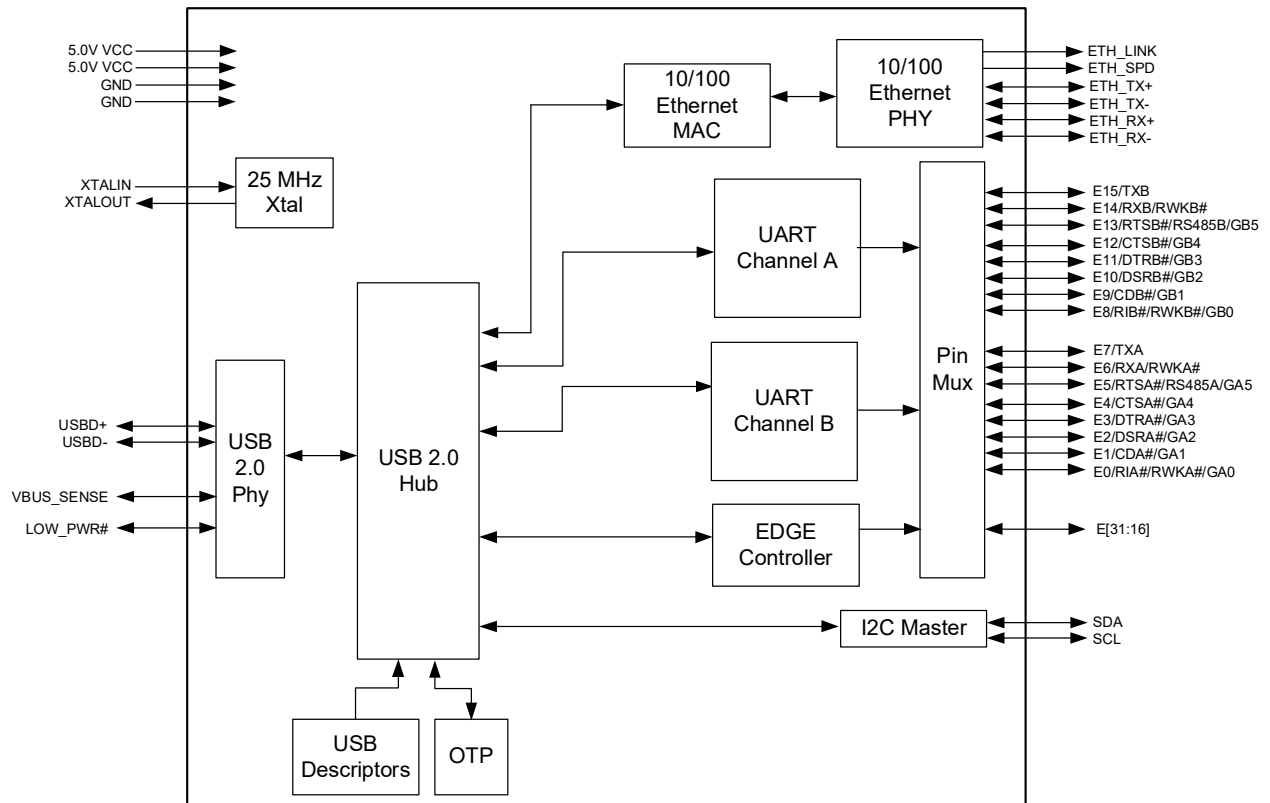



## Functional Description

### USB Interface

The XR22802 is a USB compound device with an embedded hub and 5 downstream functions. The downstream functions of the XR22802 are 10/100 Ethernet, two UART functions, an I<sup>2</sup>C function, and an Enhanced Dedicated GPIO Entity (EDGE) function. The upstream USB interface of the XR22802 is compliant with both USB 2.0 full and hi-speed specifications. All functions downstream of the hub are hi-speed functions.

The XR22802 will have a single vendor ID and vendor string. Each function in the XR22802 will have an individual product string and serial string. The default serial number strings will be based upon the uniquely assigned Ethernet MAC address for each XR22802 device. The serial strings for multiple functions within the same device will differ only by a single character which will be assigned a value between 0 and 7. All string and ID values can be overridden via OTP.

The XR22802 can be placed into a low power or suspended state by the USB host. By default the XR22802 hub is configured for bus powered mode with a maximum power of 250 mA. All other functions in the XR22802 are configured for self-powered mode. In bus powered mode, the Ethernet Phy must be powered down during suspended state to meet USB suspend power requirements. The Ethernet Phy may remain enabled to support Ethernet remote wakeup during suspend if the device is self-powered and the OTP is modified to report the hub function as self-powered in the USB descriptors. See Ethernet Remote Wakeup section on [page 11](#).

Each function of the XR22802 supports one configuration and utilizes the following USB endpoints:

- USB hub
  - Control endpoint
  - Interrupt-in endpoint
- Ethernet function
  - Control endpoint
  - Interrupt-in endpoint
  - Bulk-in and bulk-out endpoints
- I<sup>2</sup>C function
  - Control endpoint
  - Interrupt-in and interrupt-out endpoints
- EDGE Controller function
  - Control endpoint
  - Interrupt-in and interrupt-out endpoints
- UART function
  - Control endpoint
  - Interrupt-in endpoint
  - Bulk-in and bulk-out endpoints

### USB Vendor ID

Exar's USB vendor ID is 0x04E2. This is the default vendor ID that is used for the XR22802. Companies may obtain their own vendor ID, by becoming members of USB.org. The XR22802 OTP can then be modified to report this vendor ID in the USB descriptors.

### USB Product ID

Each function in the XR22802 has an individual USB product ID. The default product IDs for each of the functions are shown in Table 1. These values can be modified by programming the OTP. Companies using their own vendor ID may also select their own product IDs. Additionally, upon request MaxLinear will provide a selection of different product IDs for use with Exar's vendor ID for companies that do not wish to become members of USB.org, but wish to use their own product ID.

**Table 1: Default XR22802 Product IDs**

XR22802 Function	Default Product ID
Hub	0x0802
Ethernet 10/100	0x1300
UART Channel A	0x1400
UART Channel B	0x1401
I <sup>2</sup> C	0x1100
EDGE	0x1200

### USB Suspend

All USB peripheral devices must support the USB suspend mode. Per USB standard, the XR22802 device will begin to enter the suspend state if it does not detect any activity, (including Start of Frame or SOF packets) on its USB data lines for 3 ms. The peripheral device must then reduce power consumption from VBUS power within the next 7 ms to the allowed limit of 2.5 mA per function for the suspended state. Because the XR22802 is a compound device with 6 functions, the suspend state power limit is 15 mA for the device. Note that in this context, the "device" is all circuitry (including the XR22802) that draws power from the host VBUS.

### Remote Wakeup

When the XR22802 is suspended, the E0/RIA#/RWKA#/GA0 or the E8/RIB#/RWKB#/GB0 pins may be used to request that the host exit the suspend state if configured as an input. A high to low transition on either pin may be used to signal a remote wakeup request to the host via Exar's custom driver. However, because the two pins are internally logically ANDed, a logic '0' on either input will prevent the resume signaling. Note that the CDC-ACM driver does not support the remote wakeup feature. The E0/RIA#/RWKA#/GA0 or the E8/RIB#/RWKB#/GB0 pins may be used to signal remote wakeup by default. Additionally, the E6/RXA/RWKA# or E14/RXB/RWKB# pins, if configured as an input, may also be used for remote wakeup if enabled using the REMOTE\_WAKEUP register. The Ethernet function in the XR22802 can also be used for remote wakeup under certain conditions. Refer to Ethernet Remote Wakeup on [page 11](#).

### USB Strings

USB specifies three character string descriptors that are provided to the USB host during enumeration in string descriptors: the manufacturer, product and serial strings. In a compound device such as the XR22802, each function provides these strings to the USB host. The default manufacturer string for the XR22802 device is "Exar Corp.". The default product strings for the hub, Ethernet function, UART functions, I<sup>2</sup>C function and EDGE function are shown in [Table 2](#). The serial number string is a unique alpha-numeric ASCII string programmed into the device at the factory.

**Table 2: Default XR22802 Product Strings**

XR22802 Function	Default Product String
Hub	Exar's XR22802 Hub
Ethernet 10/100	Exar USB Ethernet
UARTs	Exar USB UART
I <sup>2</sup> C	Exar USB I2C
EDGE	Exar USB EDGE

The OTP may be used to override these strings. However, to ensure unique serial numbers for each device, it is recommended that the factory pre-programmed serial number string be used and not be overwritten via OTP.

## USB Device Drivers

Each of the functions in the XR22802 require a USB device driver for operation. Both the I<sup>2</sup>C and EDGE functions conform to the HID device class and as such, utilize the embedded HID driver that is native to each Operating System. The embedded hub also uses the native hub driver. The Ethernet function conforms to the CDC device class and as such can utilize an embedded CDC-ECM driver. However, at the time of this writing, none of the Microsoft OS provide support for CDC-ECM embedded drivers. Both Linux and Mac OS-X platforms do support CDC-ECM drivers.

The CDC-ECM driver is a class specific driver which provides functionality for USB Ethernet devices. It operates without any ability to access device specific register sets. In some cases, this can limit the functionality and / or throughput capability of the XR22802. MaxLinear provides a custom Ethernet device driver which has been optimized for the best possible data through-put in Windows and Linux platforms. This custom driver also allows for access to the device register set and thus full control of the XR22802 device functionality. Refer to 10/100 Ethernet section on [page 11](#) for more details.

The UART function can be used with either a class specific CDC-ACM driver or a custom driver. When the CDC-ACM driver is used, the driver has no ability to read or write the XR22802 device registers. Because of this, the XR22802 device is initialized to the settings in [Table 3](#). With a custom driver, all GPIOs default in hardware to inputs but these settings may be modified by a custom driver.

**Table 3: XR22802 Register Defaults With CDC-ACM Driver**

Register	Value	Notes
Flow Control	0x001	Hardware Flow Control
GPIO_MODE	0x001	RTS / CTS Flow Control
GPIO_DIRECTION	0x008	E3/DTRA#/GA3 and E11/DTRB#/GB3 are configured as outputs. All other GPIOs as inputs.
GPIO_INT_MASK	0x030	E[n]/RI#/RWK#/G[n], E[n]/CD#/G[n] and E[n]/DSR#/G[n] for both UART channels are interrupt sensitive, i.e. can cause a USB interrupt to be generated

These default settings can be overridden by programming the OTP.

If a custom driver is used, the CUSTOM\_DRIVER\_ACTIVE bit should be immediately set to '1' by the USB UART driver. Once the CUSTOM\_DRIVER\_ACTIVE bit is set, the custom driver can use standard CDC-ACM commands without configuring the device to the default register settings used with the CDC-ACM driver. Any changes to the register settings for the GPIOs and flow control will specifically need to be configured by the driver / application software. Although there is no ability to read / write registers when using the CDC-ACM driver, basic UART functions, including setting baud rate, character format and sending line break is supported by the CDC driver. Refer to the 4 CDC\_ACM\_IF USB Control Commands listed in [Table 4](#).

## 10/100 Ethernet

The Ethernet port is a 10/100 Ethernet MAC and Phy compliant with IEEE 802.3. The Ethernet port supports speed / duplex auto-negotiation, auto-MDIX, 10 Mbps data auto-polarity, full and half duplex data rates at 10 and 100 Mbps, generates and validates the 32-bit FCS, and performs unicast and multicast filtering. The XR22802 also performs TCP, UDP and ICMP checksum offload over IPV4 and IPV6 as well as header checksum offload in IPV4. On chip RAM provides all required packet buffering.

In Windows OS, using the Exar custom Ethernet driver, the properties dialog, advanced properties can be used to set the pause frame flow control, speed and duplex, auto-negotiation, checksum offload, and Ethernet remote wakeup settings. By default, the Ethernet MAC will honor incoming pause frames sent by a peer Ethernet device, but will not generate pause frames. Auto-MDIX is always enabled.

## Ethernet Remote Wakeup

If the XR22802 hub is configured as a self-powered device and has Ethernet remote wakeup enabled, the XR22802 will request the USB host to resume in response to a magic packet or a link state change on the Ethernet port. When the USB

host is suspended, the Ethernet Phy remains active and the XR22802 is able to both meet USB suspend mode power requirements as well as respond to magic packet and link state changes.

The magic packet is an Ethernet packet with specific content, i.e. 6 bytes of 0xFF, followed by 16 repetitions of the target MAC address (MAC address of the XR22802 device). This content can occur anywhere in the incoming packet payload. The link state change will wake the USB host if the link is down when the USB host is suspended and then the link goes up, or if the link is up when the USB host is suspended and then the link goes down.

## UART

The UART can be configured via USB control transfers from the USB host. The UART transmitter and receiver sections are described separately in the following sections. At power-up, the XR22802 will default to 9600 bps, 8 data bits, no parity bit, 1 stop bit, and no flow control. If a native CDC-ACM driver accesses the XR22802, defaults will change. See Remote Wakeup section on [page 10](#).

### UART transmitter

The transmitter consists of a 1024-byte TX FIFO and a Transmit Shift Register (TSR). Once a bulk-out packet has been received and the CRC has been validated, the data bytes in that packet are written into the TX FIFO of the specified UART channel. Data from the TX FIFO is transferred to the TSR when the TSR is idle or has completed sending the previous data byte. The transmitter sends the start bit followed by the data bits (starting with the LSB), inserts the proper parity-bit if enabled, and adds the stop-bit(s). The transmitter can be configured for 7 or 8 data bits with or without parity or 9 data bits without parity. If 9 bit data is selected without wide mode, the 9th bit will always be '0'.

### UART transmitter - Wide mode

When both 9 bit data and wide mode are enabled, two bytes of data must be written. The first byte that is loaded into the TX FIFO are the first 8 bits (data bits 7-0) of the 9-bit data. Bit-0 of the second byte that is loaded into the TX FIFO is bit-8 of the 9-bit data. The data that is transmitted on the TX pin is as follows: start bit, 9-bit data, stop bit. Use the TX\_WIDE\_MODE register to enable transmit wide mode.

### UART receiver

The receiver consists of a 1024-byte RX FIFO and a Receive Shift Register (RSR). Data that is received in the RSR via the RX pin is transferred into the RX FIFO. Data from the RX FIFO is sent to the USB host in response to a bulk-in request. Depending on the mode, error / status information for that data character may or may not be stored in the RX FIFO with the data.

### UART receiver - Normal mode with 7 or 8-bit data

Data that is received is stored in the RX FIFO. Any parity, framing or overrun error or break status information related to the data is discarded. Receive data format is shown in [Figure 1](#).

### UART receiver - Normal mode with 9-bit data

The first 8 bits of data received is stored in the RX FIFO. The 9th bit as well as any parity, framing or overrun error or break status information related to the data is discarded.

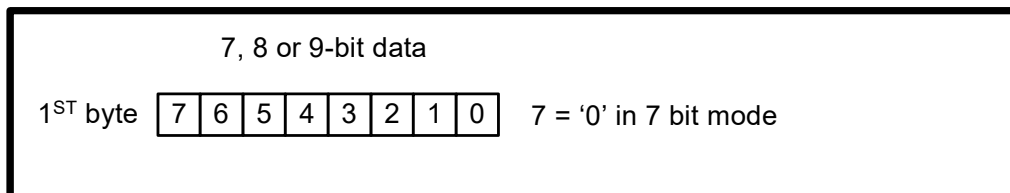

**Figure 1: UART Normal Receive Data Format with 7 or 8-bit data**

### UART receiver - Wide mode with 7 or 8-bit data

Two bytes of data are loaded into the RX FIFO for each byte of data received. The first byte is the received data. The second byte consists of the error bits and break status. Wide mode receive data format is shown in Figure 2. Use the RX\_WIDE\_MODE register to enable receive wide mode. Use the RX\_WIDE\_MODE register to enable receive wide mode.

### UART receiver - Wide mode with 9-bit data

Two bytes of data are loaded into the RX FIFO for each byte of data received. The first byte is the first 8 bits of the received data. The 9th bit received is stored in the bit 0 of the second byte. The parity bit is not received / checked. The remainder of the 2nd byte consists of the framing and overrun error bits and break status.

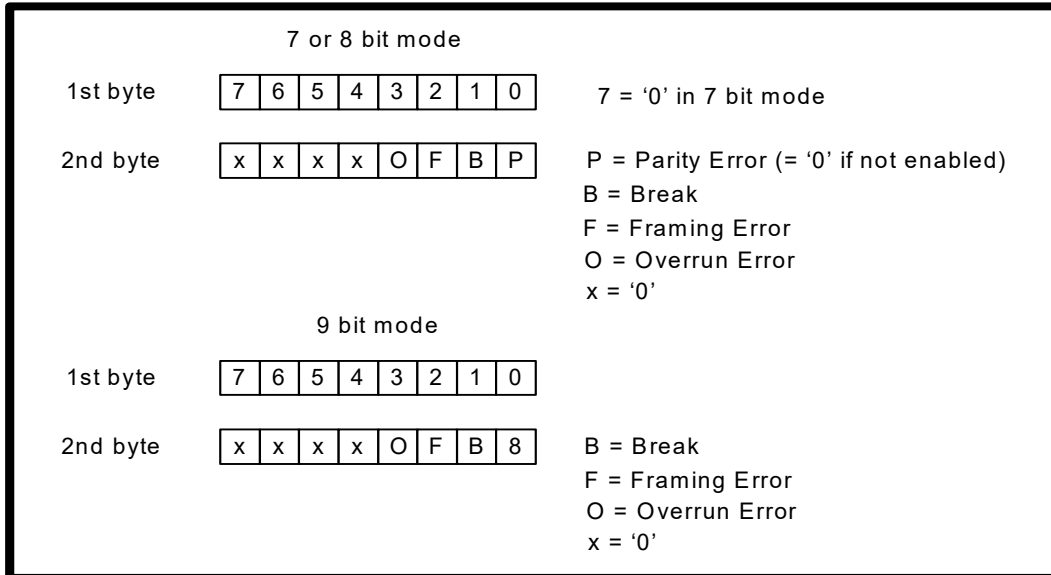

Figure 2: UART Receive Wide Mode Data Format with 7, 8 or 9-bit data

Error flags are also available from the ERROR\_STATUS register and the interrupt packet, however these flags are historical flags indicating that an error has occurred since the previous request. Therefore, no conclusion can be drawn as to which specific byte(s) may have contained an actual error in this manner.

### RX FIFO Low Latency

In normal operation all bulk-in transfers will be of maxPacketSize bytes (512 bytes in hi-speed mode and 64 bytes in full-speed mode) to improve throughput and to minimize host processing. When there are 512 / 64 bytes of data in the RX FIFO, the XR22802 will acknowledge a bulk-in request from the host and transfer the data packet. If there is less than 512 bytes in the RX FIFO, the XR22802 may NAK the bulk-in request indicating that data is not ready to transfer at that time. However, if there is less than 512 bytes in the RX FIFO and no data has been received for more than 3 character times, the XR22802 will acknowledge the bulk-in request and transfer any data in the RX FIFO to the USB host.

In some cases, especially when the baud rate is low, this increases latency unacceptably. The XR22802 has a low latency register bit that will cause the XR22802 to immediately transfer any received data in the RX FIFO to the USB host, i.e. it will not wait for 3 character times. The custom driver may automatically set the RX\_CONTROL register to force the XR22802 to be in the low latency mode, or the user may manually set this bit. With the CDC-ACM driver, the low latency mode is automatically set whenever the baud rate is set to a value of less than 46921 bps using the CDC\_ACM\_IF\_SET\_LINE\_CODING command.

## GPIO

There can be up to 8 GPIO pins in the XR22802 UART including the UART RX and TX pins. These GPIO pins may be configured as UART GPIO, or for other UART functions, e.g. RTS# function, or be assigned to the EDGE. Refer to Enhanced Dedicated GPIO Entity section on page 15.

### Automatic RTS / CTS hardware flow control

$E[n]/RTS\#/RS485/G[n]$  and  $E[n]/CTS\#/G[n]$  of the UART channel may be enabled as the RTS# and CTS# signals for Auto RTS/CTS flow control when  $GPIO\_MODE[2:0] = '001'$  and  $FLOW\_CONTROL[2:0] = '001'$ . Automatic RTS flow control is used to prevent data overrun errors in local RX FIFO by de-asserting the RTS signal to the remote UART. When there is room in the RX FIFO, the RTS pin will be re-asserted. Automatic CTS flow control is used to prevent data overrun to the remote RX FIFO. The CTS# input is monitored to suspend / restart the local transmitter (see Figure 3):

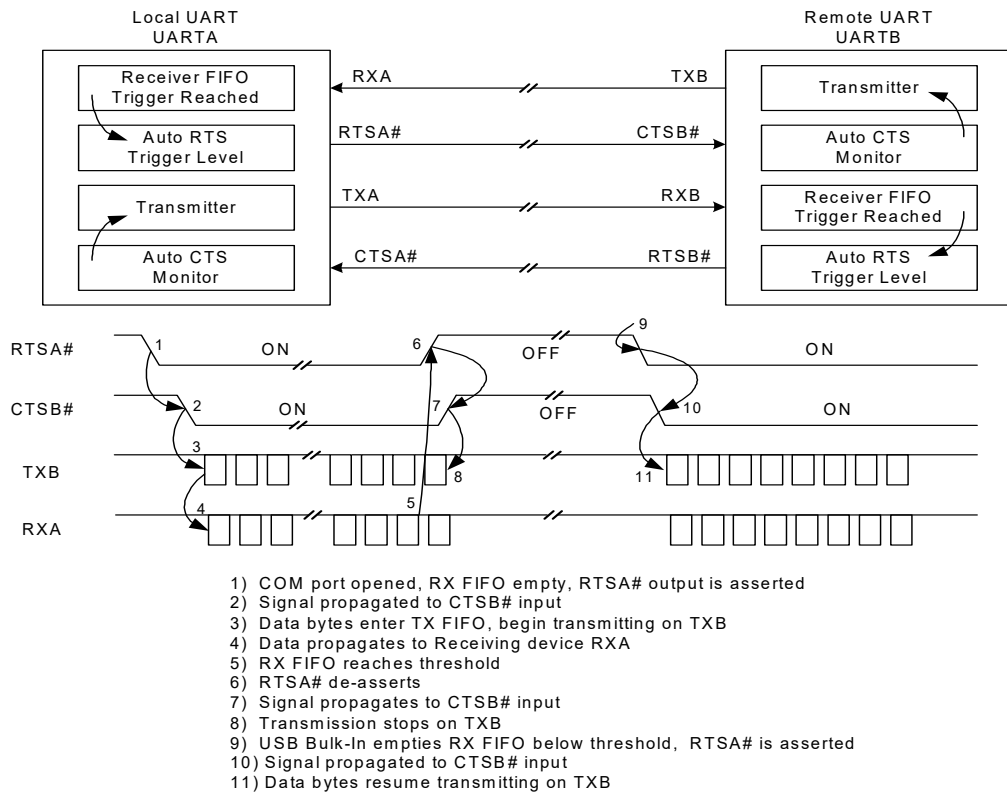

Figure 3: Auto RTS / CTS Hardware Flow Control

### Automatic DTR / DSR hardware flow control

Auto DTR/DSR hardware flow control behaves the same as the Auto RTS/CTS hardware flow control described above except that it uses the DTR# and DSR# signals. For Auto hardware flow control,  $FLOW\_CONTROL[2:0] = '001'$ .  $E[n]/DTR\#/G[n]$  and  $E[n]/DSR\#/G[n]$  become DTR# and DSR#, respectively, when  $GPIO\_MODE[2:0] = '010'$ .

### Automatic XON / XOFF software flow control

When software flow control is enabled, the XR22802 compares the receive data characters with the programmed Xon or Xoff characters. If the received character matches the programmed Xoff character, the XR22802 will halt transmission as soon as the current character has completed transmission. Data transmission is resumed when a received character matches the Xon character. Software flow control is enabled when  $FLOW\_CONTROL[2:0] = '010'$ .

### Automatic RS-485 half duplex control

The Auto RS-485 Half-Duplex Control feature changes the behavior of the E5/RTS#/RS485/G5 pin when enabled by the GPIO\_MODE register bits 2-0. See GPIO\_MODE Register Description on [page 23](#). The FLOW\_CONTROL register must also be set appropriately for use in multidrop applications. See FLOW\_CONTROL Register Description on [page 21](#). If enabled, the transmitter automatically asserts the E5/RTS#/RS485/G5 output prior to sending the data. By default, it de-asserts E[n]/RTS#/RS485/G[n] following the last stop bit of the last character that has been transmitted, but the RS485\_DELAY register may be used to delay the deassertion. The polarity of the E[n]/RTS#/RS485/G[n] signal can also be modified using the GPIO\_MODE register bit 3.

### Multidrop mode with address matching

The XR22802 device has two address matching modes which are also set by the flow control register using modes 3 and 4. These modes are intended for a multi-drop network application. In these modes, the XON\_CHAR register holds a unicast address and the XOFF\_CHAR holds a multicast address. A unicast address is used by a transmitting master to broadcast an address to all attached slave devices that is intended for only one slave device. A multicast address is used to broadcast an address intended for more than one recipient device. Each attached slave device should have a unique unicast address value stored in the XON\_CHAR register, while multiple slaves may have the same multicast address stored in the XOFF\_CHAR register. An address match occurs when an address byte (9th bit or parity bit is '1') is received that matches the value stored in either the XON\_CHAR or XOFF\_CHAR register.

### Multidrop mode receiver

If an address match occurs in either flow control mode 3 or 4, the UART Receiver will automatically be enabled and all subsequent data bytes will be loaded into the RX FIFO. The UART Receiver will automatically be disabled when an address byte is received that does not match the values in the XON\_CHAR or XOFF\_CHAR register.

### Multidrop mode transmitter

In flow control mode 3, the UART transmitter is always enabled, irrespective of the RX address match. In flow control mode 4, the UART transmitter will only be enabled if there is an RX address match.

### Programmable Turn-Around Delay

By default, the E5/RTS#/RS485/G5 pin will be de-asserted immediately after the stop bit of the last byte has been shifted. However, this may not be ideal for systems where the signal needs to propagate over long cables. Therefore, the de-assertion of E5/RTS#/RS485/G5 pin can be delayed from 1 to 15 bit times via the RS485\_DELAY register to allow for the data to reach distant UARTs.

### Half-duplex mode

Half-duplex mode is enabled when FLOW\_CONTROL[3] = 1. In this mode, the UART will ignore any data on the RX input when the UART is transmitting data.

### EDGE - Enhanced Dedicated GPIO Entity

The XR22802 has 32 IO pins that may be assigned to the EDGE. By default, 16 of these pins are assigned to the UART channel A and channel B functions, either to the UART data and / or flow control pins or to the UART GPIO. The remaining 16 pins are dedicated EDGE pins. Note that UART GPIO and EDGE have separate register controls. Pins assigned to the UART function cannot be controlled by the EDGE registers and vice versa. To assign pins to the EDGE, use the EDGE\_FUNC\_SEL\_0 register. See EDGE\_FUNC\_SEL\_0 register description on [page 38](#).

The EDGE controller allows for GPIO signals to be individually set or cleared or to be grouped, such that the all pins in the group can be simultaneously accessed for reads or writes. Note that on write accesses, output pins will change in 4-bit sub-groups on core clock (60 MHz) boundaries. For example, if an 8 bit data group is defined and the data value is written from 0x00 to 0xFF, 4 bits would change from '0' to '1' followed by the next 4 bits one clock cycle (~ 17 ns) later.

EDGE IOs can be configured as inputs or outputs. Outputs can be configured as push-pull or open drain and can be tri-stated. Inputs can be configured to generate interrupts to the USB host on either negative or positive edge transitions.

Another feature of the EDGE controller is that up to 2 GPIO pins within the EDGE can be assigned to pulse width modulated (PWM) outputs. Each of the PWM outputs can be used to generate an output clock or pulse of varying duty cycle. Both low and high cycles can be configured in steps of 267 ns up to 1.092 ms. The output can be controlled to generate a single "one-shot" pulse or to free run. Refer to the EDGE\_PWM0\_CTRL and EDGE\_PWM1\_CTRL registers on [page 44](#) and [page 45](#) for control of PWM outputs.

## I<sup>2</sup>C

The XR22802 implements an I<sup>2</sup>C multi-master using the control endpoint of the full-speed USB function to transfer data to and from the I<sup>2</sup>C interface. The I<sup>2</sup>C master supports both standard (100 kbps) and fast (400 kbps) modes and supports multiple master configurations to allow other devices to access slave devices on the I<sup>2</sup>C. The I<sup>2</sup>C function is an HID function and uses the native HID driver. It supports both 7 and 10 bit addressing modes.

## Regulated 3.3V Power Output

The XR22802 internal voltage regulator provides 3.3 VDC output power which can be utilized by other circuitry. Refer to Electrical Characteristics on [page 3](#) for maximum power capability. For bus powered devices, significant utilization of the 3V3 output power may require increasing the maximum power request above the 250 mA default value from the USB host by programming the OTP.

## OTP

The OTP is an on-chip non-volatile memory, that is one-time programmable via the USB interface. Bit locations within the memory may be programmed at various times allowing for customization of the XR22802. Some bits are pre-programmed at the factory and caution must be taken not to program any locations except user defined addresses. Contact the factory for information and assistance in programming the XR22802 OTP.



## USB Control Commands

The following table shows all of the USB Control Commands that are supported by the XR22802. Commands include standard USB commands, USB class specific CDC-ACM commands and USB vendor specific Exar commands.

**Table 4: Supported USB Control Commands**

Name	Request Type	Request	Value		Index		Length		Description
			LSB	MSB	LSB	MSB	LSB	MSB	
USB Standard Requests									
DEV GET_STATUS	0x80	0x0	0x0	0x0	0x0	0x0	0x2	0x0	Device: remote wake-up + self-powered
IF GET_STATUS	0x81	0x0	0x0	0x0	0x0	0x0	0x2	0x0	Interface: zero
EP GET_STATUS	0x82	0x0	0x0	0x0	0x0, 0x4, 0x84	0x0	0x2	0x0	Endpoint: halted
DEV CLEAR_FEATURE	0x00	0x1	0x1	0x0	0x0	0x0	0x0	0x0	Device remote wake-up
EP CLEAR_FEATURE	0x02	0x1	0x0	0x0	0x0, 0x4, 0x84	0x0	0x0	0x0	Endpoint halt
DEV SET_FEATURE	0x00	0x3	0x1	0x0	0x0	0x0	0x0	0x0	Device remote wake-up
EP SET_FEATURE	0x02	0x3	0x0	0x0	0x0, 0x4, 0x84	0x0	0x0	0x0	Endpoint halt
SET_ADDRESS	0x00	0x5	addr	0x0	0x0	0x0	0x0	0x0	addr = 1 to 127
GET_DESCRIPTOR	0x80	0x6	0x0	0x1	0x0	0x0	len MSB	len MSB	Device descriptor
GET_DESCRIPTOR	0x80	0x6	0x0	0x2	LangID	LangID	len MSB	len MSB	Configuration descriptor
GET_DESCRIPTOR	0x80	0x6	0x0	0x3	0x0	0x0	len MSB	len MSB	String descriptor
GET_CONFIGURATION	0x80	0x8	0x0	0x0	0x0	0x0	0x1	0x0	
SET_CONFIGURATION	0x00	0x9	n	0x0	0x0	0x0	0x0	0x0	n = 0, 1
USB Class Specific Requests									
CDC_ACM_IF SET_LINE_CODING	0x21	0x20	0x0	0x0	0x0	0x0	0x7	0x0	Set the UART baud rate, parity, stop bits, etc.
CDC_ACM_IF GET_LINE_CODING	0xA1	0x21	0x0	0x0	0x0	0x0	0x7	0x0	Get the UART baud rate, parity, stop bits, etc.
CDC_ACM_IF SET_CONTROL_LINE_STATE	0x21	0x22	0x0	0x0	0x0	0x0	0x7	0x0	Set/Clear DTR in CDC-ACM mode.
CDC_ACM_IF SEND_BREAK	0x21	0x23	val LSB	val MSB	0x0	0x0	0x0	0x0	Send a break for the specified duration.

Table 4: Supported USB Control Commands

Name	Request Type	Request	Value		Index		Length		Description
			LSB	MSB	LSB	MSB	LSB	MSB	
CDC_ECM_IF_SET_ETH_MCAST_FILTERS	0x21	0x40	Number (N) of filters LSB	Number (N) of filters MSB	0x0	0x0	N*6 LSB	N*6 MSB	
CDC_ECM_IF_SET_ETH_PACKET_FILTERS	0x21	0x43	*Bit-map LSB	*Bit-map MSB	0x0	0x0	0x0	0x0	See Bitmap definition in note 1 below
CDC_ECM_IF_GET_ETH_STATISTIC	0xA1	0x44	Selector	0x0	0x0	0x0	0x4	0x0	See Selector definition in note 2 below
USB Vendor Specific Requests									
XR_GET_CHIP_ID	0xC0	0xFF	0x0	0x0	0x0	0x0	0x6	0x0	Get Exar VID (2 bytes), PID (2 bytes) and bcdDevice (2 bytes)
XR_SET_REG See Table 5	0x40	0x5	write-data LSB	write-data MSB	write addr	0x0	0x0	0x0	Vendor specific register access.
XR_GET_REG See Table 5	0xC0	0x5	0x0	0x0	read addr	0x0	0x2	0x0	Vendor specific register access.

Note 1: SET\_ETH\_PACKET\_FILTERS Bitmap definition:

D15..D5: reserved

D4: MULTICAST If 1, packets with multicast addresses set by SetEthernetMulticastFilter are forwarded to the host. 0 = Disabled.

D3: BROADCAST If 1, broadcast packets are forwarded to the host. 0 = Disabled.

D2: DIRECTED If 1, unicast packets with a matching address are forwarded to the host. 0 = Disabled.

D1: ALL\_MULTICAST If 1, all multicast packets are forwarded to the host. 0 = Disabled.

D0: PROMISCUOUS If 1, all packets are forwarded to the host, regardless of address. 0 = Disabled.

Note 2: SET\_ETH\_PACKET\_FILTERS Selector definition:

0x01 = XMIT\_OK

0x02 = RCV\_OK

0x03 = XMIT\_ERROR

0x04 = RCV\_ERROR

0x05 = RCV\_NO\_BUFFER

0x0d = DIRECTED\_FRAME\_RCV

0x0f = MULTICAST\_FRAME\_RCV

0x11 = BROADCAST\_FRAME\_RCV

0x12 = RCV\_CRC\_ERROR

0x13 = XMIT\_QUEUE\_LENGTH

0x14 = RCV\_ERR\_ALIGNMENT

0x19 = RCV\_OVERRUN

## UART Registers

UART registers are accessible via the USB interface using the XR\_SET\_REG and XR\_GET\_REG USB commands. Note that all addresses not listed in this table are reserved or undefined. Upper byte (bits 15:8) not shown in table are also reserved and should remain 0x00. Writing to any register other than those defined in Table 5 may result in undefined behavior of the device. The addresses for each of UARTs in the XR22802 are the same. Because each UART is assigned a unique USB address during enumeration by the USB host, a GUI connected to a specific COM port will be directed via the driver to the appropriate UART channel.

### UART Register Map

Table 5: XR22802 Register Map

Address	Register Name	Bit 7 (15)	Bit 6 (14)	Bit 5 (13)	Bit 4 (12)	Bit 3 (11)	Bit 2 (10)	Bit 1 (9)	Bit 0 (8)
0x040	UART_ENABLE	0	0	0	0	0	0	RX	TX
0x045	FORMAT	STOP	PARITY			DATA_BITS			
0x046	FLOW_CONTROL	0	0	0	0	AUTO_RS485	MODE		
0x047	XON_CHAR	CHAR							
0x048	XOFF_CHAR	CHAR							
0x049	ERROR_STATUS	BREAK_ACTIVE	OVER-RUN	PARITY	FRAME	BREAK	0	0	0
0x04A	TX_BREAK (MSB)	VALUE [MSB]							
	TX_BREAK (LSB)	VALUE [LSB]							
0x04B	RS485_DELAY	0	0	0	0	VALUE			
0x04C	GPIO_MODE	0	0	0	0	RS485_POL	MODE		
0x04D	GPIO_DIRECTION	0	0	GPIO5	GPIO4	GPIO3	GPIO2	GPIO1	GPIO0
0x04E	GPIO_SET	0	0	GPIO5	GPIO4	GPIO3	GPIO2	GPIO1	GPIO0
0x04F	GPIO_CLEAR	0	0	GPIO5	GPIO4	GPIO3	GPIO2	GPIO1	GPIO0
0x050	GPIO_STATUS	0	0	GPIO5	GPIO4	GPIO3	GPIO2	GPIO1	GPIO0
0x051	GPIO_INT_MASK	0	0	GPIO5	GPIO4	GPIO3	GPIO2	GPIO1	GPIO0
0x052	CUSTOMIZED_INT	0	0	0	0	0	0	0	EN
0x054	PIN_PULLUP_EN	TX	RX	GPIO5	GPIO4	GPIO3	GPIO2	GPIO1	GPIO0
0x055	PIN_PULLDOWN_EN	TX	RX	GPIO5	GPIO4	GPIO3	GPIO2	GPIO1	GPIO0
0x056	LOOPBACK	0	0	0	0	0	DTR_DSR	RTS_CTS	TX_RX
0x057	IR_MODE	0	0	0	0	0	TX_PULSE	RX_INVERT	EN
0x05F	REMOTE_WAKEUP	0	0	0	0	RX_EN	RI_EN	0	0
0x060	TX_FIFO_RESET	0	0	0	0	0	0	0	RST

Table 5: XR22802 Register Map

Address	Register Name	Bit 7 (15)	Bit 6 (14)	Bit 5 (13)	Bit 4 (12)	Bit 3 (11)	Bit 2 (10)	Bit 1 (9)	Bit 0 (8)
0x061	TX_FIFO_FILL (MSB)	0	0	0	0	FILL[10:8]			
	TX_FIFO_FILL (LSB)	FILL[7:0]							
0x062	TX_WIDE_MODE	0	0	0	0	0	0	0	EN
0x063	RX_FIFO_RESET	0	0	0	0	0	0	0	RST
0x064	RX_FIFO_FILL (MSB)	0	0	0	0	0	FILL[10:8]		
	RX_FIFO_FILL (LSB)	FILL[7:0]							
0x065	RX_WIDE_MODE	0	0	0	0	0	0	0	EN
0x066	RX_CONTROL	0	0	0	0	0	0	MAX_PKT_SIZE	LOW_LATENCY
0x067	FLOW_THRESHOLD (MSB)	0	0	0	0	0	THRESH [10:8]		
	FLOW_THRESHOLD (LSB)	THRESH [7:0]							
Miscellaneous Registers									
0x081	CUSTOM_DRIVER	0	0	0	0	0	0	0	ACTIVE

### UART Register Descriptions

Note that all register reset default values are '0' unless otherwise specified. All registers are 16 bits.

#### UART\_ENABLE (0x040) - Read/Write

Bit	Default	Description
15:2	0x0000	<b>Reserved</b> These bits are reserved and should be written as '0'.
1	0	<b>RX</b> 0: Disable UART RX 1: Enable UART RX
0	0	<b>TX</b> 0: Disable UART TX 1: Enable UART TX

**FORMAT (0x045) - Read/Write**

Note that the CDC\_SET\_LINE\_CODING command may be used to set the UART data format in addition to this registers.

Bit	Default	Description
15:8	0x00	<b>Reserved</b> These bits are reserved and should be written as '0'.
7	0	<b>Stop</b> 0: 1 stop bit 1: 2 stop bits
6:4	0	<b>Parity</b> 000: No parity 001: Odd parity 010: Even parity 011: Mark parity 100: Space parity All other values undefined, do not use.
3:0	0x8	<b>Data_Bits</b> 0111: 7-bit characters 1000: 8-bit characters 1001: 9-bit characters All other values undefined, do not use.

**FLOW\_CONTROL (0x046) - Read/Write**

Bit	Default	Description
15:4	0x000	<b>Reserved</b> These bits are reserved and should be written as '0'.
3	0	<b>Half-Duplex Mode</b> 0: UART RX received data irrespective of UART TX 1: UART RX is disabled when UART TX is transmitting data
2:0	0	<b>Mode</b> 000: None 001: Hardware 010: Software 011: Address match RX 100: Address match RX and TX All other values undefined, do not use.

**XON\_CHAR (0x047) - Read/Write**

Bit	Default	Description
15:8	0x00	<b>Reserved</b> These bits are reserved and should be written as '0'.
7:0	0x11	<b>Char</b> XON ASCII character received in hexadecimal format

**XOFF\_CHAR (0x048) - Read/Write**

Bit	Default	Description
15:8	0x00	<b>Reserved</b> These bits are reserved and should be written as '0'.
7:0	0x13	<b>Char</b> XOFF ASCII character received in hexadecimal format

**ERROR\_STATUS (0x049) - Read Only**

Bit	Default	Description
15:8	0x00	<b>Reserved</b> These bits are reserved and should be written as '0'.
7	0	<b>Break_Active</b> 0: No break condition currently active 1: Break condition currently active
6	0	<b>Overrun</b> 0: No overrun error detected 1: Overrun error detected since last register read
5	0	<b>Parity</b> 0: No parity error detected 1: Parity error detected since last register read
4	0	<b>Frame</b> 0: No frame error detected 1: Frame error detected since last register read
3	0	<b>Break</b> 0: No break error detected 1: Break error detected since last register read
2:0	0	<b>Reserved</b> These bits are reserved and should be written as '0'.

**TX\_BREAK (0x04A) - Read/Write**

Bit	Default	Description
15:0	0x0000	<p><b>Value</b></p> <p>This register controls transmission of break signal. Writing a non-zero value "N" to this registers causes the XR22802 to send a break signal on the UART TX pin for "N" ms, for <math>0 &lt; N &lt; 0xFFFF</math>. A counter will decrement this value at 1 ms intervals until the count reaches 0x0 at which time the break signal will stop being sent. Writing a value of 0xFFFF causes a continuous break signal to be sent, until either a value of 0x0 is written or another non-zero value other than 0xFFFF which will again cause break signal to stop after the counter expires.</p>

**RS485\_DELAY (0x04B) - Read/Write**

Bit	Default	Description
15:4	0x000	<p><b>Reserved</b></p> <p>These bits are reserved and should be written as '0'.</p>
3:0	000	<p><b>Value</b></p> <p>This value is the number of bit times the XR22802 waits before de-asserting the E5/RTS#/RS485/G5 pin when it is configured for automatic RS-485 half-duplex control.</p>

**GPIO\_MODE (0x04C) - Read/Write**

Bit	Default	Description
15:4	0x000	<p><b>Reserved</b></p> <p>These bits are reserved and should be written as '0'.</p>
3	0	<p><b>RS485 Polarity</b></p> <p>0: Active low auto. RS-485 half-duplex enable 1: Active high auto. RS-485 half-duplex enable</p>
2:0	0x0	<p><b>GPIO Mode</b></p> <p>000: Mode 0 - All GPIO are used for general purpose I/O. 001: Mode 1 - E5/RTS#/RS485/G5 and E4/CTS#/G4 used for Auto RTS/CTS HW Flow Control 010: Mode 2 - E3/DTR#/G3 and E2/DSR#/G2 used for Auto DTR/DSR HW Flow Control 011: Mode 3 - E5/RTS#/RS485/G5 pin used for auto RS-485 half-duplex enable during Transmit 100: Mode 4 - E5/RTS#/RS485/G5 pin used for auto RS-485 half-duplex enable after address match. 101 to 111: Reserved values, do not use.</p>

**GPIO\_DIRECTION (0x04D) - Read/Write**

Note that when setting direction of a UART GPIO to output, the PIN\_PULLUP\_EN for that IO pin should also be disabled and when setting a UART GPIO pin to input, the PIN\_PULLUP\_EN for that IO pin should also be enabled.

Bit	Default	Description
15:6	0x000	<b>Reserved</b> These bits are reserved and should be written as '0'.
5:0	0x00	<b>GPIO[N] Direction</b> 0: GPIO[N] is an input 1: GPIO[N] is an output

**GPIO\_SET (0x04E) - Write Only**

Bit	Default	Description
15:6	0x000	<b>Reserved</b> These bits are reserved and should be written as '0'.
5:0	0x00	<b>GPIO[N] Set</b> 0: No effect 1: Set GPIO[N] if configured as an output to a logic '1'

**GPIO\_CLEAR (0x04F) - Write Only**

Bit	Default	Description
15:6	0x000	<b>Reserved</b> These bits are reserved and should be written as '0'.
5:0	0x00	<b>GPIO[N] Clear</b> 0: No effect 1: Clear GPIO[N] if configured as an output to a logic '0'

**GPIO\_STATUS (0x050) - Read Only**

Bit	Default	Description
15:6	0x000	<b>Reserved</b> These bits are reserved and should be written as '0'.
5:0	0x00	<b>GPIO[N] Status</b> Reading returns the current state of GPIO[N].



**GPIO\_INT\_MASK (0x051) - Read/Write**

Bit	Default	Description
15:6	0x000	<b>Reserved</b> These bits are reserved and should be written as '0'.
5:0	0x00	<b>GPIO[N] Mask</b> Dictates whether a change in GPIO pin state causes the device to generate a USB interrupt packet. In either case, the GPIO status register will still report the pin's state when read, and if an interrupt packet is formed due to other interrupt trigger, the interrupt packet will contain the current state of the pin.  0: A change in the pin's state causes the device to generate an interrupt packet. 1: A change in the pin's state does not cause the device to generate an interrupt packet.'

**CUSTOMIZED\_INT (0x052) - Read/Write**

Bit	Default	Description
15:1	0x0000	<b>Reserved</b> These bits are reserved and should be written as '0'.
0	0	<b>Enable</b> Enables the customized interrupt packet format to report all GPIO status in the interrupt packet.  0: Use standard interrupt packet. See Table 6 and Table 7. 1: Use customized interrupt packet. See Table 8.

**Table 6: Interrupt Packet Format**

Offset	Field	Size (Bytes)	Value	Description
0	bmRequestType	1	8'b10100001	D7 = Device-to-host direction D6:5 = Class Type D4-0: = Interface Recipient
1	bNotification	1	8'h20	Defined encoding for SERIAL_STATE
2	wValue	2	16'h0000	
4	wIndex	2	16'h0000	D15-8 = Reserved (0) D7-0 = Interface number, 8'h00 for the CDC Command Interface
6	wLength	2	16'h0002	2 bytes of transferred data
8	Data	2	Standard int_status (See ) For customized int_status Size = 4 bytes (See Table 7 and )Table 8	D15-7 = Reserved (0) D6 = bOverRun D5 = bParity D4 = bFraming D3 = bRingSignal (RI) D2 = bBreak D1 = bTxCarrier (DSR) D0 = bRxCarrier (CD)

**Table 7: Data Field of Standard Interrupt Packet**

Bits	Field	Description
D15..D7		Reserved (future use)
D6	bOverRun	Received data has been discarded due to overrun in the device.
D5	bParity	A parity error has occurred.
D4	bFraming	A framing error has occurred.
D3	bRingSignal	State of ring signal detection of the device.
D2	bBreak	State of break detection mechanism of the device.
D1	bTxCarrier	State of transmission carrier. This signal corresponds to V.24 signal 106 and RS-232 signal DSR.
D0	bRxCarrier	State of receiver carrier detection mechanism of device. This signal corresponds to V.24 signal 109 and RS-232 signal DCD.

**Table 8: Data Field of Customized Interrupt Packet - Exar Vendor Specific**

Bit(s)	Description
31-20	Reserved (0)
19	Overrun
18	Parity Error
17	Frame Error
16	Break Status
15-14	Reserved (0)
13	RTS state
12	CTS state
11	DTR state
10	DSR state
9	CD state
8	RI state
7-6	Reserved (0)
5	RTS change
4	CTS change
3	DTR change
2	DSR change
1	CD change
0	RI change

Overrun, Parity Error, Frame Error, and Break all indicate that at least one event has occurred since the last interrupt message. "State" reflects the high/low state of the pin at the time the Interrupt Data IN packet was generated. "Change" indicates whether the level on the pin changed at least once since the last interrupt message.

**PIN\_PULLUP\_EN (0x054) - Read/Write**

Bit	Default	Description
15:8	0	<b>Reserved</b> These bits are reserved and should be written as '0'.
7	1	<b>UART TX</b> 0: Disable internal pull-up resistor on the UART TX pin 1: Enable internal pull-up resistor on the UART TX pin
6	1	<b>UART RX</b> 0: Disable internal pull-up resistor on the UART RX pin 1: Enable internal pull-up resistor on the UART RX pin
5:0	0x3F	<b>GPIO[N]</b> 0: Disable internal pull-up resistor on the corresponding GPIO[N] pin 1: Enable internal pull-up resistor on the corresponding GPIO[N] pin

**PIN\_PULLDOWN\_EN (0x055) - Read/Write**

Bit	Default	Description
15:10	0	<b>Reserved</b> These bits are reserved and should be written as '0'.
7	0	<b>UART TX</b> 0: Disable internal pull-down resistor on the UART TX pin 1: Enable internal pull-down resistor on the UART TX pin. (Will not be enabled if pull-up is already enabled.)
6	0	<b>UART RX</b> 0: Disable internal pull-down resistor on the UART RX pin 1: Enable internal pull-down resistor on the UART RX pin. (Will not be enabled if pull-up is already enabled.)
5:0	0	<b>GPIO[N]</b> 0: Disable internal pull-down resistor on the corresponding GPIO[N] pin 1: Enable internal pull-down resistor on the corresponding GPIO[N] pin. (Will not be enabled if pull-up is already enabled.)

**LOOPBACK (0x056) - Read/Write**

Bit	Default	Description
15:3	0	<b>Reserved</b> These bits are reserved and should be written as '0'.
2	0	<b>DTR_DSR</b> 0: Disable DTR to DSR internal loopback 1: Enable DTR to DSR internal loopback
1	0	<b>RTS_CTS</b> 0: Disable RTS to CTS internal loopback 1: Enable RTS to CTS internal loopback
0	0	<b>TX_RX</b> When this bit is set all transmitted UART data is looped back to the UART receiver. Note that when the internal loopback is enabled, the Tx data will be disabled and Rx data will be ignored.  0: Disable TX to RX internal loopback 1: Enable TX to RX internal loopback

**IR\_MODE (0x057) - Read/Write**

Bit	Default	Description
15:3	0	<b>Reserved</b> These bits are reserved and should be written as '0'.
2	0	<b>TX_Pulse</b> 0: TX pulse width is 3/16 of the bit period 1: TX pulse width is 4/16 of the bit period
1	0	<b>RX_Invert</b> 0: RX input is not inverted before sampling 1: RX input is inverted before sampling
0	0	En 0: Disable IR mode 1: Enable IR mode

**REMOTE\_WAKEUP (0x05F) - Read/Write**

Bit	Default	Description
15:4	0x000	<b>Reserved</b> These bits are reserved and should be written as '0'.
3	0	<b>RX_En</b> 0: RX pin remote wakeup is disabled 1: A high to low transition on the RX pin will cause a resume request to be sent to the USB host
2	1	<b>RI_En</b> 0: RI# pin remote wakeup is disabled 1: A high to low transition on the RI# pin will cause a resume request to be sent to the USB host
1:0	0x0	<b>Reserved</b> These bits are reserved and should be written as '0'.

**TX\_FIFO\_RESET (0x060) - Write Only**

Bit	Default	Description
15:1	0x0000	<b>Reserved</b> These bits are reserved and should be written as '0'.
0	000	<b>Reset</b> 0: No effect 1: Resets the TX FIFO to empty

**TX\_FIFO\_FILL (0x061) - Read Only**

Bit	Default	Description
15:11	0x00	<b>Reserved</b> These bits are reserved and should be written as '0'.
10:0	0x000	<b>Fill</b> Number of bytes in the TX FIFO

**TX\_WIDE\_MODE (0x062) - Read/Write**

Bit	Default	Description
15:1	0x0000	<b>Reserved</b> These bits are reserved and should be written as '0'.
0	0	<b>EN</b> In wide mode, 2 bytes of data are used to transfer one character. This requires 2 bytes of FIFO space, therefore the FIFO can hold half as many characters in wide mode. In the TX direction bit 0 of the second byte will be used as bit 9 of the character, if 9-bit mode is enabled. Bits 7:1 of the second byte are not used.  0: Disable TX wide mode 1: Enable TX wide mode

**RX\_FIFO\_RESET (0x063) - Write Only**

Bit	Default	Description
15:1	0x0000	<b>Reserved</b> These bits are reserved and should be written as '0'.
0	000	<b>Reset</b> 0: No effect 1: Resets the RX FIFO to empty

**RX\_FIFO\_FILL (0x064) - Read Only**

Bit	Default	Description
15:11	0x00	<b>Reserved</b> These bits are reserved and should be written as '0'.
10:0	0x000	<b>Fill</b> Number of bytes in the RX FIFO

**RX\_WIDE\_MODE (0x065) - Read/Write**

Bit	Default	Description
15:1	0x0000	<b>Reserved</b> These bits are reserved and should be written as '0'.
0	0	<b>EN</b> In wide mode, 2 bytes of Bulk data are used to transfer one character. This requires 2 bytes of FIFO space, therefore the FIFO can hold half as many characters in wide mode. In the RX direction, bits 3:0 of the second byte contain the error flags associated with the character. Bits 7:4 of the second byte are not used.  0: Disable RX wide mode 1: Enable RX wide mode

**RX\_CONTROL (0x066) - Read/Write**

Bit	Default	Description
15:2	0	<b>Reserved</b> These bits are reserved and should be written as '0'.
1	0	<b>Max_Pkt_Size</b> 0: Maximum bulk-in packet size is 512 / 64 bytes in hi-speed / full-speed mode respectively (normal operation) 1: Maximum bulk-in packet size is 508 / 60 bytes in hi-speed / full-speed mode respectively (workaround for known Windows OS CDC-ACM driver issue)
0	0	<b>Low_Latency</b> 0: Disable low latency mode 1: Enable low latency mode

**FLOW\_THRESHOLD (0x067) - Read/Write**

Bit	Default	Description
15:11	0x0	<b>Reserved</b> These bits are reserved and should be written as '0'.
10:0	0x2E0	<b>Thresh</b> If enabled, flow control (either hardware or software), will be asserted when the RX FIFO fill level exceeds the threshold value.

**CUSTOM\_DRIVER (0x081) - Read/Write**

Bit	Default	Description
15:1	0x0000	<b>Reserved</b> These bits are reserved and should be written as '0'.
0	0	<b>Active</b> A custom driver should immediately enable this bit prior to using any CDC-ACM commands from the USB host, to ensure that the XR22802 does not enter CDC mode and default to the values listed in <a href="#">Table 3</a> .

## HID Reports

The I<sup>2</sup>C and EDGE functions in the XR22802 are HID functions. I<sup>2</sup>C data may be read or written to / from the slave device using the interrupt in and interrupt out endpoints via HID input and output reports. Additionally, XR22802 device register access using the control endpoint for both I<sup>2</sup>C and EDGE functions is performed via HID feature reports. Reading uses indirect addressing such that for register reads, the register address must first be written and the register value may then be read. Both types of reports are described below.

### Input and Output Reports

Input and output reports using the interrupt in and interrupt out endpoints follow the following format.

#### I2C\_SLAVE\_OUT

Transfer Type: Interrupt Out

Transfer Size: 37 bytes

The I2C\_SLAVE\_OUT report writes and / or reads up to 32 bytes of data on the I<sup>2</sup>C interface. Note that all interrupt out transfers will be automatically followed by an interrupt in transfer. For write only transfers, the interrupt in packet will contain the status of the interrupt out transfer. For read only or write and read transfers, the interrupt in packet will contain the read data, as well as the status of the interrupt out transfer. The format of the interrupt out packet is given below.

Field	Offset	Size	Value	Description
Report ID	0	1	0x00	Write, read, or write and read I <sup>2</sup> C data
Flags	1	1	Bitmap	Transfer options D0: Prefix transfer with a start bit. D1: Append a stop bit to the transfer. D2: ACK last read to extend a read transfer (e.g. if more than 32 bytes need to be read). The default is to NAK the last read in the transfer. This bit has no effect if RdSize is 0. D3: Reserved D7.D4: Sequence number. This can help the host to correlate an IN response with a prior OUT command. This field is optional.
WrSize	2	1	Number	Number of data bytes to write. Valid values are 0 to 32. The 7-bit slave address should not be included in this total.
RdSize	3	1	Number	Number of bytes to read. Valid values are 0 to 32.
SlaveAddr	4	1	Number	The 7-bit slave address* to send. The XR22802 will automatically set the I2 C read/write bit, so bit D0 of this field is ignored.
Data	5	32	Data	Data to be written to the slave. HID uses a fixed report size for each specific report ID so this field will always be 32 bytes long. However, only the number of bytes specified in WrSize will be written. Other bytes will be ignored.

\* Note: To support 10-bit addressing the standard 7-bit address must be set to 1111 0xxB where xx are the most significant bits of the 10-bit address. All 4 of these 7-bit addresses are reserved and will not be used by any slaves with 7-bit only addresses. The least significant bit of the address byte still specifies the direction. For writes, the first data byte which was previously unformatted is now reserved for the least significant 8 bits of the 10-bit address. Additional data bytes remain unformatted. For reads, the write-then-read combined transfer format is always used. During the write portion of the combined transfer the master must send at least one data byte which contains the least significant 8 bits of the 10-bit address. After all of the write data is sent the master then sends a restart bit. This is followed with an address byte which has the same 7-bit address 1111 0xxB as in the write portion. However, the direction bit is now 1 for reading. The slave then sends the read data as usual. The least significant 8 bits of the 10-bit address are not sent again after the restart bit.



**I2C\_SLAVE\_IN**

Transfer Type: Interrupt In

Transfer Size: 36 bytes

Interrupt in packet status only, or status and read data from the I2C interface.

Field	Offset	Size	Value	Description
Flags	0	1	Bitmap	Status of the requested transfer. D0: Request Error. If 1, the OUT request had an error (e.g. invalid size) and was not executed. D1: A byte sent to a slave received an I2C NAK response. The transfer was aborted. D2: Arbitration was lost. The transfer was aborted. D3: Timeout. Bus free condition was not observed within 256 ms or an individual byte transfer extended longer than 10ms. D7.D4: Sequence number. This number matches the value provided in the corresponding OUT command packet.
WrSize	1	1	Number	Number of bytes written, 0 to 32.
RdSize	2	1	Number	Number of bytes read, 0 to 32.
Reserved	3	1	Number	This field is reserved.
Data	4	32	Data	The read data that was received from the slave. HID uses a fixed report size for each specific report ID, so this field will always be 32 bytes long. However, only the number of bytes specified in RdSize are valid. Other bytes should be ignored.

**Feature Reports**

Access to XR22802 registers via HID feature reports along with the register descriptions are given in the following sections.

**WRITE\_HID\_REGISTER**

Transfer Type: Control

Transfer Size: 5 bytes

The WRITE\_HID\_REGISTER report writes 2 bytes of data to the specified register address.

Field	Offset	Size	Value	Description
Report ID	0	1	0x3C	Write HID register
Write Address LSB	1	1		Write address
Write Address MSB	2	1		
Write Data LSB	3	1		Write data
Write Data MSB	4	1		

**SET\_HID\_READ\_ADDRESS**

Transfer Type: Control

Transfer Size: 3 bytes

The SET\_HID\_READ\_ADDRESS report sets the address for the READ\_HID\_REGISTER report.

Field	Offset	Size	Value	Description
Report ID	0	1	0x4B	Set address for HID register read
Read Address LSB	1	1		Read address
Read Address MSB	2	1		

**READ\_HID\_REGISTER**

Transfer Type: Control

Transfer Size: 3 bytes

The READ\_HID\_REGISTER report reads register data from the address set by the SET\_HID\_READ\_ADDRESS report.

Field	Offset	Size	Value	Description
Report ID	0	1	0x5A	Read HID register
Read Data LSB	1	1		Read data
Read Data MSB	2	1		

## HID Register Map

Table 9: XR22802 HID Register Map

Address	Register Name	Bit 7 (15)	Bit 6 (14)	Bit 5 (13)	Bit 4 (12)	Bit 3 (11)	Bit 2 (10)	Bit 1 (9)	Bit 0 (8)
I <sup>2</sup> C Registers									
0x341	I <sup>2</sup> C_SCL_LOW MSB [15:8]	VALUE (MSB)							
	I <sup>2</sup> C_SCL_LOW LSB [7:0]	VALUE (LSB)							
0x342	I <sup>2</sup> C_SCL_HIGH MSB [15:8]	VALUE (MSB)							
	I <sup>2</sup> C_SCL_HIGH LSB [7:0]	VALUE (LSB)							
EDGE Registers									
0x3C0	EDGE_FUNC_SEL_0 [15:8]	E15	E14	E13	E12	E11	E10	E9	E8
	EDGE_FUNC_SEL_0 [7:0]	E7	E6	E5	E4	E3	E2	E1	E0
0x3C1	EDGE_DIR_0 [15:8]	E15	E14	E13	E12	E11	E10	E9	E8
	EDGE_DIR_0 [7:0]	E7	E6	E5	E4	E3	E2	E1	E0
0x3C2	EDGE_SET_0 [15:8]	E15	E14	E13	E12	E11	E10	E9	E8
	EDGE_SET_0 [7:0]	E7	E6	E5	E4	E3	E2	E1	E0
0x3C3	EDGE_CLEAR_0 [15:8]	E15	E14	E13	E12	E11	E10	E9	E8
	EDGE_CLEAR_0 [7:0]	E7	E6	E5	E4	E3	E2	E1	E0
0x3C4	EDGE_STATE_0 [15:8]	E15	E14	E13	E12	E11	E10	E9	E8
	EDGE_STATE_0 [7:0]	E7	E6	E5	E4	E3	E2	E1	E0
0x3C5	EDGE_TRI_STATE_0 [15:8]	E15	E14	E13	E12	E11	E10	E9	E8
	EDGE_TRI_STATE_0 [7:0]	E7	E6	E5	E4	E3	E2	E1	E0
0x3C6	EDGE_OPEN_DRAIN_0 [15:8]	E15	E14	E13	E12	E11	E10	E9	E8
	EDGE_OPEN_DRAIN_0 [7:0]	E7	E6	E5	E4	E3	E2	E1	E0
0x3C7	EDGE_PULL_UP_0 [15:8]	E15	E14	E13	E12	E11	E10	E9	E8
	EDGE_PULL_UP_0 [7:0]	E7	E6	E5	E4	E3	E2	E1	E0
0x3C8	EDGE_PULL_DOWN_0 [15:8]	E15	E14	E13	E12	E11	E10	E9	E8
	EDGE_PULL_DOWN_0 [7:0]	E7	E6	E5	E4	E3	E2	E1	E0
0x3C9	EDGE_INTR_MASK_0 [15:8]	E15	E14	E13	E12	E11	E10	E9	E8
	EDGE_INTR_MASK_0 [7:0]	E7	E6	E5	E4	E3	E2	E1	E0

Table 9: XR22802 HID Register Map

Address	Register Name	Bit 7 (15)	Bit 6 (14)	Bit 5 (13)	Bit 4 (12)	Bit 3 (11)	Bit 2 (10)	Bit 1 (9)	Bit 0 (8)
0x3CA	EDGE_INTR_POS_EDGE_0 [15:8]	E15	E14	E13	E12	E11	E10	E9	E8
	EDGE_INTR_POS_EDGE_0 [7:0]	E7	E6	E5	E4	E3	E2	E1	E0
0x3CB	EDGE_INTR_NEG_EDGE_0 [15:8]	E15	E14	E13	E12	E11	E10	E9	E8
	EDGE_INTR_NEG_EDGE_0 [7:0]	E7	E6	E5	E4	E3	E2	E1	E0
0x3CD	EDGE_DIR_1 [31:24]	E31	E30	E29	E28	E27	E26	E25	E24
	EDGE_DIR_1 [23:16]	E23	E22	E21	E20	E19	E18	E17	E16
0x3CE	EDGE_SET_1 [31:24]	E31	E30	E29	E28	E27	E26	E25	E24
	EDGE_SET_1 [23:16]	E23	E22	E21	E20	E19	E18	E17	E16
0x3CF	EDGE_CLEAR_1 [31:24]	E31	E30	E29	E28	E27	E26	E25	E24
	EDGE_CLEAR_1 [23:16]	E23	E22	E21	E20	E19	E18	E17	E16
0x3D0	EDGE_STATE_1 [31:24]	E31	E30	E29	E28	E27	E26	E25	E24
	EDGE_STATE_1 [23:16]	E23	E22	E21	E20	E19	E18	E17	E16
0x3D1	EDGE_TRI_STATE_1 [31:24]	E31	E30	E29	E28	E27	E26	E25	E24
	EDGE_TRI_STATE_1 [23:16]	E23	E22	E21	E20	E19	E18	E17	E16
0x3D2	EDGE_OPEN_DRAIN_1 [31:24]	E31	E30	E29	E28	E27	E26	E25	E24
	EDGE_OPEN_DRAIN_1 [23:16]	E23	E22	E21	E20	E19	E18	E17	E16
0x3D3	EDGE_PULL_UP_1 [31:24]	E31	E30	E29	E28	E27	E26	E25	E24
	EDGE_PULL_UP_1 [23:16]	E23	E22	E21	E20	E19	E18	E17	E16
0x3D4	EDGE_PULL_DOWN_1 [31:24]	E31	E30	E29	E28	E27	E26	E25	E24
	EDGE_PULL_DOWN_1 [23:16]	E23	E22	E21	E20	E19	E18	E17	E16
0x3D5	EDGE_INTR_MASK_1 [31:24]	E31	E30	E29	E28	E27	E26	E25	E24
	EDGE_INTR_MASK_1 [23:16]	E23	E22	E21	E20	E19	E18	E17	E16
0x3D6	EDGE_INTR_POS_EDGE_1 [31:24]	E31	E30	E29	E28	E27	E26	E25	E24
	EDGE_INTR_POS_EDGE_1 [23:16]	E23	E22	E21	E20	E19	E18	E17	E16

Table 9: XR22802 HID Register Map

Address	Register Name	Bit 7 (15)	Bit 6 (14)	Bit 5 (13)	Bit 4 (12)	Bit 3 (11)	Bit 2 (10)	Bit 1 (9)	Bit 0 (8)
0x3D7	EDGE_INTR_NEG_EDGE_1 [31:24]	E31	E30	E29	E28	E27	E26	E25	E24
	EDGE_INTR_NEG_EDGE_1 [23:16]	E23	E22	E21	E20	E19	E18	E17	E16
0x3D8	EDGE_PWM0_CTRL MSB [15:8]	0	0	0	0	0	0	0	CMD[2]
	EDGE_PWM0_CTRL LSB [7:0]	CMD[1:0]		EN	PIN[4:0]				
0x3D9	EDGE_PWM0_HIGH MSB [15:8]	0	0	0	0	VALUE[11:8]			
	EDGE_PWM0_HIGH LSB [7:0]	VALUE [7:0]							
0x3DA	EDGE_PWM0_LOW MSB [15:8]	0	0	0	0	VALUE[11:8]			
	EDGE_PWM0_LOW LSB [7:0]	VALUE [7:0]							
0x3DB	EDGE_PWM1_CTRL MSB [15:8]	0	0	0	0	0	0	0	CMD[2]
	EDGE_PWM1_CTRL LSB [7:0]	CMD[1:0]		EN	PIN[4:0]				
0x3DC	EDGE_PWM1_HIGH MSB [15:8]	0	0	0	0	VALUE[11:8]			
	EDGE_PWM1_HIGH LSB [7:0]	VALUE [7:0]							
0x3DD	EDGE_PWM1_LOW MSB [15:8]	0	0	0	0	VALUE[11:8]			
	EDGE_PWM1_LOW LSB [7:0]	VALUE [7:0]							

## HID Register Descriptions

Note that all register reset default values are '0' unless otherwise specified. All registers are 16 bits.

### I<sup>2</sup>C\_SCL\_LOW (0x341) - Read/Write

Bit	Default	Description
15:0	0x0144	<p><b>Value</b></p> <p>Specifies the number of periods that SCL will be asserted low by the XR22802 I<sup>2</sup>C master. Note that in clock stretching, the I<sup>2</sup>C slave may extend the SCL low period to delay the next transaction. For 100 kbps transfer rate this value must be at least 252 (0x00FC) and the sum of high and low periods must be at least 600 (0x0258). For 400kbps transfer rate this value must be at least 78 (0x004E) and the sum of the high and low periods must be at least 150 (0x0096). Measured in 60 MHz core clock periods, i.e. approximately 16.7 ns.</p>

### I<sup>2</sup>C\_SCL\_HIGH (0x342) - Read/Write

Bit	Default	Description
15:0	0x0114	<p><b>Value</b></p> <p>Specifies the number of periods that SCL will be asserted high by the XR22802 I<sup>2</sup>C master. Note that another multi-master may assert SCL low before the XR22802 high period is completed. For 100 kbps transfer rate this value must be at least 240 (0x00F0) and the sum of the high and low periods must be at least 600 (0x0258). For 400 kbps transfer rate this value must be at least 36 (0x0024) and the sum of the high and low periods must be at least 150 (0x0096). Measured in 60 MHz core clock periods, i.e. approximately 16.7 ns</p>

### EDGE\_FUNC\_SEL\_0 (0x3C0) - Read/Write

Bit	Default	Description
15:0	0x0000	<p><b>E[15:0]</b></p> <p>0: IO is assigned to the UART / GPIO function. IO pin controlled using UART registers. 1: IO is assigned to the EDGE function. IO pin controlled using EDGE registers.</p>

### EDGE\_DIR\_0 (0x3C1) - Read/Write

Note that when setting direction of an EDGE IO to output, the EDGE\_PULL\_UP for that IO pin should also be disabled and when setting an EDGE IO pin to input, the EDGE\_PULL\_UP for that IO pin should also be enabled.

Bit	Default	Description
15:0	0x0000	<p><b>E[15:0]</b></p> <p>0: IO pin assigned to EDGE function is configured as an input 1: IO pin assigned to EDGE function is configured as an output.</p>

**EDGE\_SET\_0 (0x3C2) - Write Only**

Bit	Default	Description
15:0	0x0000	<b>E[15:0]</b> 0: No effect 1: Set IO pin assigned to EDGE function and configured as an output to a logic '1'

**EDGE\_CLEAR\_0 (0x3C3) - Write Only**

Bit	Default	Description
15:0	0x0000	<b>E[15:0]</b> 0: No effect 1: Clear IO pin assigned to EDGE function and configured as an output to a logic '0'

**EDGE\_STATE\_0 (0x3C4) - Read/Write**

Bit	Default	Description
15:0	0x0000	<b>E[15:0]</b> Writing in this register sets or clears the EDGE IO pin(s) configured as an output. Writing to an EDGE pin configured as an input has no effect. Reading this register returns the state of each IO pin configured as an EDGE pin irrespective of whether it is configured as an input or output. Note that output transitions across multiple IO pins may be slightly staggered. Refer to EDGE section on page 15.  0: Write clears the corresponding bit to a '0'. Read returns the current state. 1: Write sets the corresponding bit to a '1'. Read returns the current state.

**EDGE\_TRI\_STATE\_0 (0x3C5) - Read/Write**

Bit	Default	Description
15:0	0x0000	<b>E[15:0]</b> 0: IO pin assigned to EDGE function and configured as an output is actively driven 1: IO pin assigned to EDGE function and configured as an output is tri-stated

**EDGE\_OPEN\_DRAIN\_0 (0x3C6) - Read/Write**

Bit	Default	Description
15:0	0x0000	<b>E[15:0]</b> Note that XR22802 open drain outputs have a weak internal pull-up.  0: IO pin assigned to EDGE function and configured as an output is a push-pull output 1: IO pin assigned to EDGE function and configured as an output is an open drain output

**EDGE\_PULL\_UP\_0 (0x3C7) - Read/Write**

Bit	Default	Description
15:0	0xFFFF	<b>E[15:0]</b> 0: Disable internal pull-up resistor on IO pin assigned to EDGE function and configured as an input 1: Enable internal pull-up resistor on IO pin assigned to EDGE function and configured as an input

**EDGE\_PULL\_DOWN\_0 (0x3C8) - Read/Write**

Bit	Default	Description
15:0	0x0000	<b>E[15:0]</b> 0: Disable internal pull-down resistor on IO pin assigned to EDGE function and configured as an input 1: Enable internal pull-down resistor on IO pin assigned to EDGE function and configured as an input

**EDGE\_INTR\_MASK\_0 (0x3C9) - Read/Write**

Bit	Default	Description
15:0	0x0000	<b>E[15:0]</b> Writing a '1' in this register enables an input pin for the corresponding bit position EDGE IO pin(s) configured as an input to generate an interrupt if either EDGE_INTR_POS_EDGE and / or EDGE_INTR_NEG_EDGE registers has also been enabled. An EDGE pin configured as an output has no effect.  0: IO pin will not generate an interrupt 1: IO pin assigned to EDGE function and configured as an input will generate an interrupt

**EDGE\_INTR\_POS\_EDGE\_0 (0x3CA) - Read/Write**

Bit	Default	Description
15:0	0xFFFF	<b>E[15:0]</b> Writing a '1' in this register enables an interrupt to be generated on the rising edge of the corresponding bit position EDGE IO pin(s) configured as an input if the EDGE_INTR_MASK register is enabled for that pin. If the EDGE_INTR_NEG_EDGE register is also enabled, interrupts will be generated on both edges. Writing to an EDGE pin configured as an output has no effect.  0: IO pin will not generate an interrupt on rising edge 1: IO pin assigned to EDGE function and configured as an input will generate an interrupt on rising edge if corresponding EDGE_INTR_MASK bit is set



**EDGE\_INTR\_NEG\_EDGE\_0 (0x3CB) - Read/Write**

Bit	Default	Description
15:0	0xFFFF	<p><b>E[15:0]</b>            Writing a '1' in this register enables an interrupt to be generated on the falling edge of the corresponding bit position EDGE IO pin(s) configured as an input if the EDGE_INTR_MASK register is enabled for that pin. If the EDGE_INTR_POS_EDGE register is also enabled, interrupts will be generated on both edges. Writing to an EDGE pin configured as an output has no effect.</p> <p>0: IO pin will not generate an interrupt on falling edge            1: IO pin assigned to EDGE function and configured as an input will generate an interrupt on falling edge if corresponding EDGE_INTR_MASK bit is set</p>

**EDGE\_DIR\_1 (0x3CD) - Read/Write**

Note that when setting direction of an EDGE IO to output, the EDGE\_PULL\_UP for that IO pin should also be disabled and when setting an EDGE IO pin to input, the EDGE\_PULL\_UP for that IO pin should also be enabled.

Bit	Default	Description
31:16	0x0000	<p><b>E[31:16]</b>            0: IO pin assigned to EDGE function is configured as an input            1: IO pin assigned to EDGE function is configured as an output.</p>

**EDGE\_SET\_1 (0x3CE) - Write Only**

Bit	Default	Description
31:16	0x0000	<p><b>E[31:16]</b>            0: No effect            1: Set IO pin assigned to EDGE function and configured as an output to a logic '1'</p>

**EDGE\_CLEAR\_1 (0x3CF) - Write Only**

Bit	Default	Description
31:16	0x0000	<p><b>E[31:16]</b>            0: No effect            1: Clear IO pin assigned to EDGE function and configured as an output to a logic '0'</p>

**EDGE\_STATE\_1 (0x3D0) - Read/Write**

Bit	Default	Description
31:16	0x0000	<p><b>E[31:16]</b>            Writing in this register sets or clears the EDGE IO pin(s) configured as an output. Writing to an EDGE pin configured as an input has no effect. Reading this register returns the state of each IO pin configured as an EDGE pin irrespective of whether it is configured as an input or output. Note that output transitions across multiple IO pins may be slightly staggered. Refer to EDGE section on <a href="#">page 15</a>.</p> <p>0: Write clears the corresponding bit to a '0'. Read returns the current state.            1: Write sets the corresponding bit to a '1'. Read returns the current state.</p>

**EDGE\_TRI\_STATE\_1 (0x3D1) - Read/Write**

Bit	Default	Description
31:16	0x0000	<p><b>E[31:16]</b>            0: IO pin assigned to EDGE function and configured as an output is actively driven            1: IO pin assigned to EDGE function and configured as an output is tri-stated</p>

**EDGE\_OPEN\_DRAIN\_1 (0x3D2) - Read/Write**

Bit	Default	Description
31:16	0x0000	<p><b>E[31:16]</b>            Note that XR22802 open drain outputs have a weak internal pull-up.</p> <p>0: IO pin assigned to EDGE function and configured as an output is a push-pull output            1: IO pin assigned to EDGE function and configured as an output is an open drain output</p>

**EDGE\_PULL\_UP\_1 (0x3D3) - Read/Write**

Bit	Default	Description
31:16	0xFFFF	<p><b>E[31:16]</b>            0: Disable internal pull-up resistor on IO pin assigned to EDGE function and configured as an input            1: Enable internal pull-up resistor on IO pin assigned to EDGE function and configured as an input</p>

**EDGE\_PULL\_DOWN\_1 (0x3D4) - Read/Write**

Bit	Default	Description
31:16	0x0000	<p><b>E[31:16]</b>            0: Disable internal pull-down resistor on IO pin assigned to EDGE function and configured as an input            1: Enable internal pull-down resistor on IO pin assigned to EDGE function and configured as an input</p>

**EDGE\_INTR\_MASK\_1 (0x3D5) - Read/Write**

Bit	Default	Description
31:16	0x0000	<p><b>E[31:16]</b>            Writing a '1' in this register enables an input pin for the corresponding bit position EDGE IO pin(s) configured as an input to generate an interrupt if either EDGE_INTR_POS_EDGE and / or EDGE_INTR_NEG_EDGE registers has also been enabled. An EDGE pin configured as an output has no effect.</p> <p>0: IO pin will not generate an interrupt            1: IO pin assigned to EDGE function and configured as an input will generate an interrupt</p>

**EDGE\_INTR\_POS\_EDGE\_1 (0x3D6) - Read/Write**

Bit	Default	Description
31:16	0xFFFF	<p><b>E[31:16]</b>            Writing a '1' in this register enables an interrupt to be generated on the rising edge of the corresponding bit position EDGE IO pin(s) configured as an input if the EDGE_INTR_MASK register is enabled for that pin. If the EDGE_INTR_NEG_EDGE register is also enabled, interrupts will be generated on both edges. Writing to an EDGE pin configured as an output has no effect.</p> <p>0: IO pin will not generate an interrupt on rising edge            1: IO pin assigned to EDGE function and configured as an input will generate an interrupt on rising edge if corresponding EDGE_INTR_MASK bit is set</p>

**EDGE\_INTR\_NEG\_EDGE\_1 (0x3D7) - Read/Write**

Bit	Default	Description
31:16	0xFFFF	<p><b>E[31:16]</b>            Writing a '1' in this register enables an interrupt to be generated on the falling edge of the corresponding bit position EDGE IO pin(s) configured as an input if the EDGE_INTR_MASK register is enabled for that pin. If the EDGE_INTR_POS_EDGE register is also enabled, interrupts will be generated on both edges. Writing to an EDGE pin configured as an output has no effect.</p> <p>0: IO pin will not generate an interrupt on falling edge            1: IO pin assigned to EDGE function and configured as an input will generate an interrupt on falling edge if corresponding EDGE_INTR_MASK bit is set</p>

**EDGE\_PWM0\_CTRL (0x3D8) - Read/Write**

Bit	Default	Description
15:9	0x00	<b>Reserved</b> These bits are reserved and should be written as '0'.
8:6	0x0	<b>Cmd</b> 000: Idle. output pin remains at same state 001: Undefined, do not use 010: Undefined, do not use 011: Undefined, do not use 100: Assert logic '0' 101: One-shot -If previous state was assert '0', one-shot pulse will be high, If previous state was assert '1', one-shot pulse will be low 110: Free run output 111: Assert logic '0'
5	0	<b>Enable</b> 0: PWM0 output is not enabled 1: PWM0 output is enabled on pin specified in Pin field using mode specified in Cmd field
4:0	0x00	<b>Pin</b> Specifies which pin (E31 - E0) will be assigned to PWM0 output.

**EDGE\_PWM0\_HIGH (0x3D9) - Read/Write**

Bit	Default	Description
15:12	0x0	<b>Reserved</b> These bits are reserved and should be written as '0'.
11:0	0x001	<b>Value</b> This register specifies the high period for PWM0 in increments of 266.667ns. High period must be in the range of 1 to 4095 (266.667 ns to 1.092 ms)

**EDGE\_PWM0\_LOW (0x3DA) - Read/Write**

Bit	Default	Description
15:12	0x0	<b>Reserved</b> These bits are reserved and should be written as '0'.
11:0	0x001	<b>Value</b> This register specifies the low period for PWM0 in increments of 266.667ns. Low period must be in the range of 1 to 4095 (266.667 ns to 1.092 ms)

**EDGE\_PWM1\_CTRL (0x3DB) - Read/Write**

Bit	Default	Description
15:9	0x00	<b>Reserved</b> These bits are reserved and should be written as '0'.
8:6	0x0	Cmd 000: Idle. output pin remains at same state 001: Undefined, do not use 010: Undefined, do not use 011: Undefined, do not use 100: Assert logic '0' 101: One-shot -If previous state was assert '0', one-shot pulse will be high, If previous state was assert '1', one-shot pulse will be low 110: Free run output 111: Assert logic '0'
4:0	0x00	Pin Specifies which pin (E31 - E0) will be assigned to PWM1 output.

**EDGE\_PWM1\_HIGH (0x3DC) - Read/Write**

Bit	Default	Description
15:12	0x0	<b>Reserved</b> These bits are reserved and should be written as '0'.
11:0	0x001	<b>Value</b> This register specifies the high period for PWM1 in increments of 266.667ns. High period must be in the range of 1 to 4095 (266.667 ns to 1.092 ms)

**EDGE\_PWM1\_LOW (0x3DD) - Read/Write**

Bit	Default	Description
15:12	0x0	<b>Reserved</b> These bits are reserved and should be written as '0'.
11:0	0x001	<b>Value</b> This register specifies the low period for PWM1 in increments of 266.667ns. Low period must be in the range of 1 to 4095 (266.667 ns to 1.092 ms)

Mechanical Dimensions

56-Pin QFN

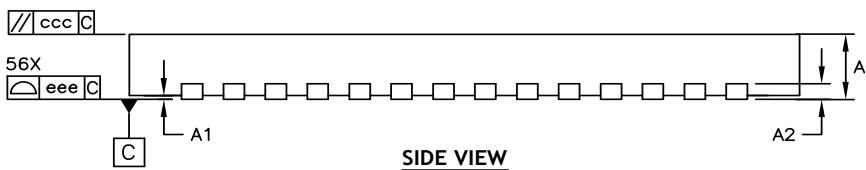
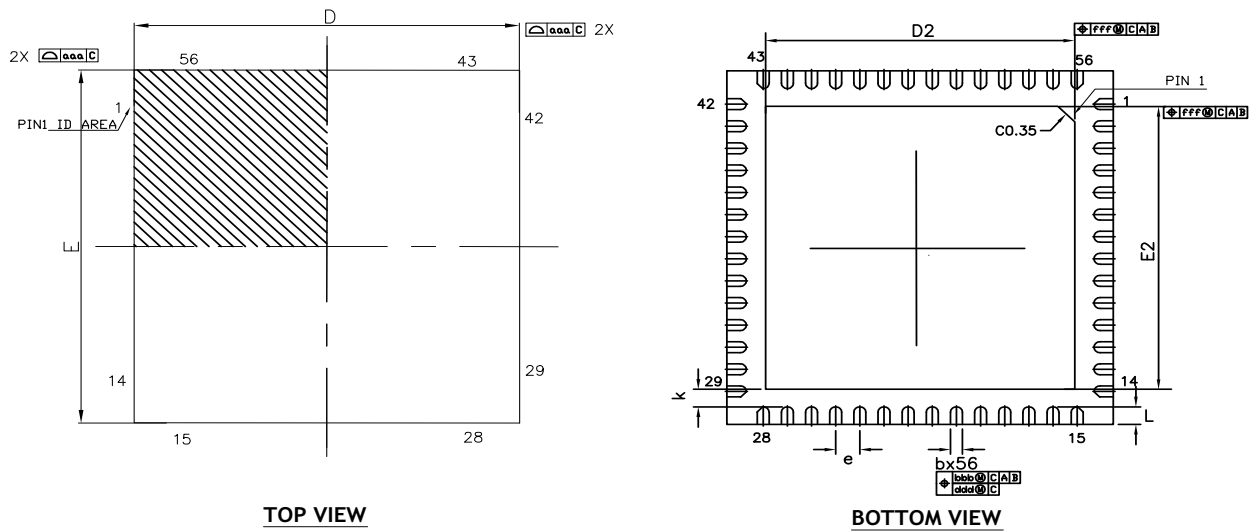

DIM SYMBOL	MIN	NOM	MAX
A	0.80	0.90	1.00
A1	0.00	0.02	0.05
A2	---	0.20Ref	---
b	0.18	0.25	0.30
D	8.00 BSC		
E	8.00 BSC		
e	0.50 BSC		
D2	6.30	6.40	6.50
E2	6.30	6.40	6.50
L	0.30	0.40	0.50
K	0.40	—	—
aaa		0.15	
bbb		0.10	
ccc		0.10	
ddd		0.05	
eee		0.08	
fff		0.10	
N		56	

TERMINAL DETAILS

- ALL DIMENSIONS ARE IN MILLIMETERS, ANGLES ARE IN DEGREES.
- DIMENSIONS AND TOLERANCE PER JEDEC MO-220.

Drawing No.: POD-00000129

Revision: B

Recommended Land Pattern and Stencil

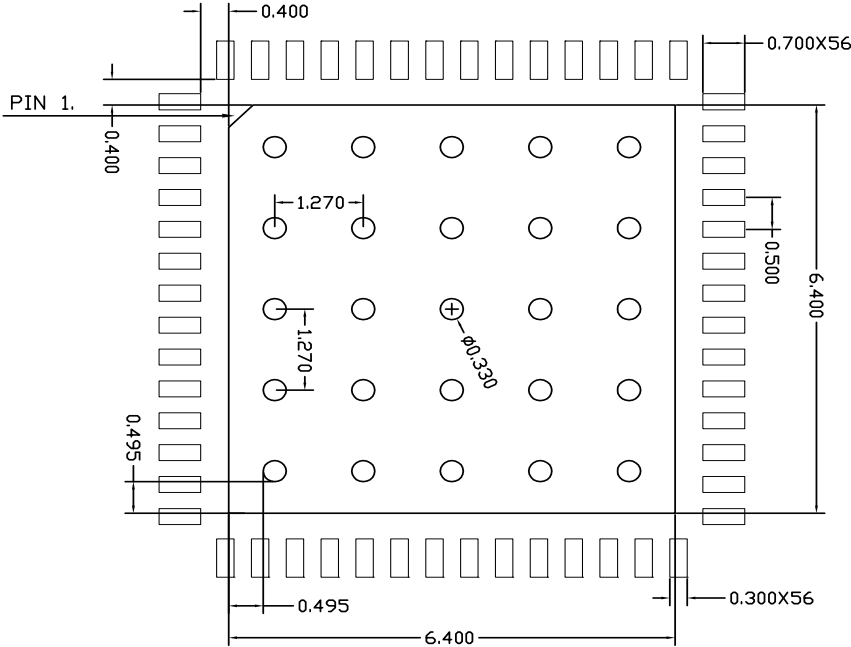

TYPICAL RECOMMENDED LAND PATTERN

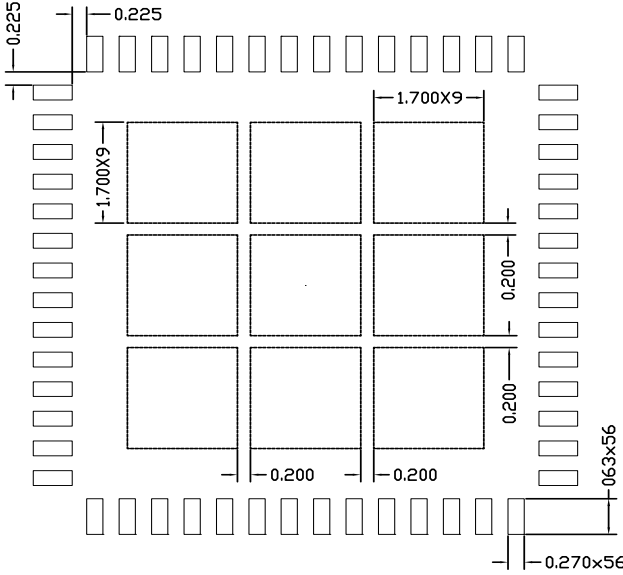

TYPICAL RECOMMENDED STENCIL

Drawing No.: POD-00000129

Revision: B

## Ordering Information<sup>(1)</sup>

Part Number	Operating Temperature Range	Lead-Free	Package	Packaging Method
XR22802IL56-F	-40°C to +85°C	Yes <sup>(2)</sup>	56-pin QFN	Tray
XR22802IL56-0A-EB	XR22802 Evaluation Board			

### NOTES:

1. Refer to [www.maxlinear.com/XR22802](http://www.maxlinear.com/XR22802) for most up-to-date Ordering Information.
2. Visit [www.maxlinear.com](http://www.maxlinear.com) for additional information on Environmental Rating.

## Revision History

Revision	Date	Description
1A	July 2014	Initial Release
1B	April 2015	Corrected VBUS_SENSE pin definition and Table 1 hub PID. Corrected Request Values for CDC_ACM_IF and added 3 CDC_ECM_IF commands to Table 4 USB Commands. Added descriptions of feature and input and output reports for HID functions. Added HID register access feature reports. [ECN 1518-03 Apr 28 2015]
1C	February 2018	Update to MaxLinear logo. Update format and ordering information table. Renamed center pad and added to Pin Assignments. Added defaults to E16-E31 pins. Updated custom software drivers on page 2. Changed standard driver to class specific driver in USB Device Drivers section and to native in UART section.
1D	March 2019	Update I2C_SLAVE_IN register table. Update Ordering Information.



### Corporate Headquarters:

5966 La Place Court  
 Suite 100  
 Carlsbad, CA 92008  
 Tel.: +1 (760) 692-0711  
 Fax: +1 (760) 444-8598  
[www.maxlinear.com](http://www.maxlinear.com)

The content of this document is furnished for informational use only, is subject to change without notice, and should not be construed as a commitment by MaxLinear, Inc.. MaxLinear, Inc. assumes no responsibility or liability for any errors or inaccuracies that may appear in the informational content contained in this guide. Complying with all applicable copyright laws is the responsibility of the user. Without limiting the rights under copyright, no part of this document may be reproduced into, stored in, or introduced into a retrieval system, or transmitted in any form or by any means (electronic, mechanical, photocopying, recording, or otherwise), or for any purpose, without the express written permission of MaxLinear, Inc.

MaxLinear, Inc. does not recommend the use of any of its products in life support applications where the failure or malfunction of the product can reasonably be expected to cause failure of the life support system or to significantly affect its safety or effectiveness. Products are not authorized for use in such applications unless MaxLinear, Inc. receives, in writing, assurances to its satisfaction that: (a) the risk of injury or damage has been minimized; (b) the user assumes all such risks; (c) potential liability of MaxLinear, Inc. is adequately protected under the circumstances.

MaxLinear, Inc. may have patents, patent applications, trademarks, copyrights, or other intellectual property rights covering subject matter in this document. Except as expressly provided in any written license agreement from MaxLinear, Inc., the furnishing of this document does not give you any license to these patents, trademarks, copyrights, or other intellectual property.

Company and product names may be registered trademarks or trademarks of the respective owners with which they are associated.

© 2015 - 2019 MaxLinear, Inc. All rights reserved